

SKT 1400



Capsule Thyristor

Line Thyristor

SKT 1400

Features

- Hermetic metal case with ceramic insulator
- Capsule package for double sided cooling
- Shallow design with single sided cooling
- Off-state and reverse voltages up to 3600 V
- Amplifying gate

Typical Applications*

- DC motor control (e. g. for machine tools)
- Controlled rectifiers (e. g. for battery charging)
- AC controllers (e. g. for temperature control)
- Soft starters for AC motors
- Recommended snubber network e. g. for $V_{VRMS} \leq 400$ V:
 $R = 33 \Omega / 32$ W, $C = 1 \mu F$

V_{RSM} V	V_{RRM}, V_{DRM} V	$I_{TRMS} = 3000$ A (maximum value for continuous operation) $I_{TAV} = 1400$ A (sin. 180; DSC; $T_c = 66$ °C)	
2700	2600	SKT 1400/26E	
2900	2800	SKT 1400/28E	
3300	3200	SKT 1400/32E	
3700	3600	SKT 1400/36E	

Symbol	Conditions	Values	Units
I_{TAV}	sin. 180; $T_c = 100$ (85) °C;	786 (1090)	A
I_D	2 x N4/250; $T_a = 45$ °C; B2 / B6	1700 / 2400	A
	2 x N4/400; $T_a = 45$ °C; B2 / B6	1900 / 2600	A
I_{RMS}	2 x N4/250; $T_a = 45$ °C; W1C	1900	A
I_{TSM}	$T_{vj} = 25$ °C; 10 ms	29000	A
	$T_{vj} = 125$ °C; 10 ms	25000	A
i^2t	$T_{vj} = 25$ °C; 8,3 ... 10 ms	4200000	A ² s
	$T_{vj} = 125$ °C; 8,3 ... 10 ms	3125000	A ² s
V_T	$T_{vj} = 25$ °C; $I_T = 3000$ A	max. 2,1	V
$V_{T(TO)}$	$T_{vj} = 125$ °C	max. 1,04	V
r_T	$T_{vj} = 125$ °C	max. 0,35	mΩ
I_{DD}, I_{RD}	$T_{vj} = 125$ °C; $V_{RD} = V_{RRM}, V_{DD} = V_{DRM}$	max. 100	mA
t_{gd}	$T_{vj} = 25$ °C; $I_G = 1$ A; $di_G/dt = 1$ A/μs	1	μs
t_{gr}	$V_D = 0,67 * V_{DRM}$	2	μs
$(di/dt)_{cr}$	$T_{vj} = 125$ °C	max. 150	A/μs
$(dv/dt)_{cr}$	$T_{vj} = 125$ °C	max. 1000	V/μs
t_q	$T_{vj} = 125$ °C	200 ... 300	μs
I_H	$T_{vj} = 25$ °C; typ. / max.	500 / 1000	mA
I_L	$T_{vj} = 25$ °C; typ. / max.	2000 / 5000	mA
V_{GT}	$T_{vj} = 25$ °C; d.c.	min. 3	V
I_{GT}	$T_{vj} = 25$ °C; d.c.	min. 300	mA
V_{GD}	$T_{vj} = 125$ °C; d.c.	max. 0,25	V
I_{GD}	$T_{vj} = 125$ °C; d.c.	max. 10	mA
$R_{th(j-c)}$	cont.; DSC	0,018	K/W
$R_{th(j-c)}$	sin. 180; DSC / SSC	0,0185 / 0,039	K/W
$R_{th(j-c)}$	rec. 120; DSC / SSC	0,02 / 0,041	K/W
$R_{th(c-s)}$	DSC / SSC	0,003 / 0,006	K/W
T_{vj}		- 40 ... + 125	°C
T_{stg}		- 40 ... + 130	°C
V_{isol}		-	V~
F	mounting force	27 ... 34	kN
a			m/s ²
m	approx.	1000	g
Case		B 19	



SKT

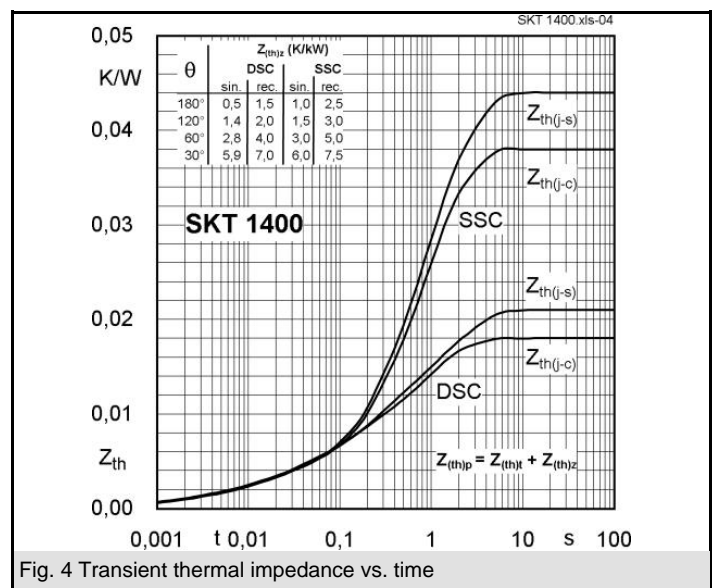
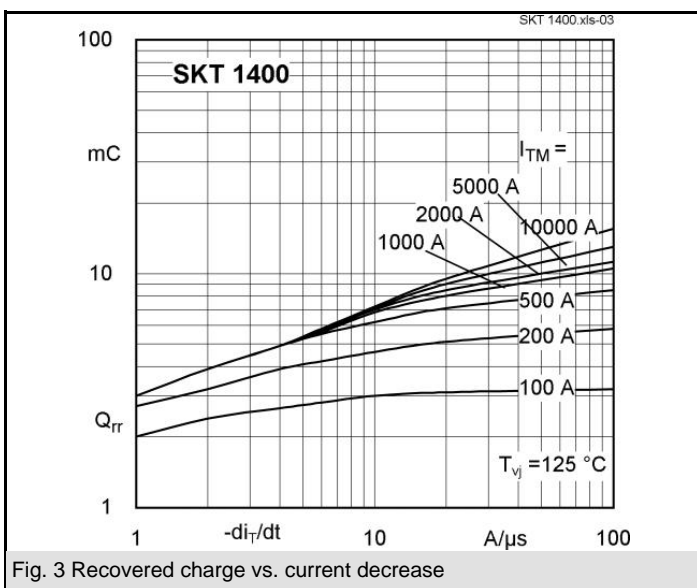
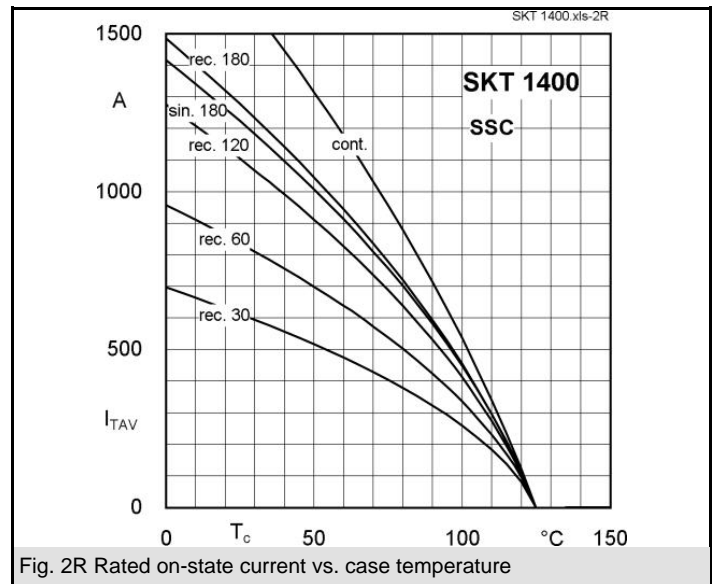
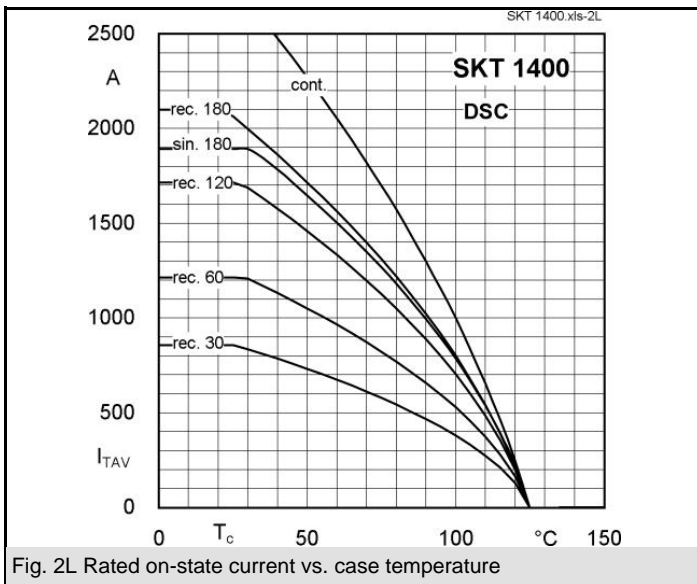
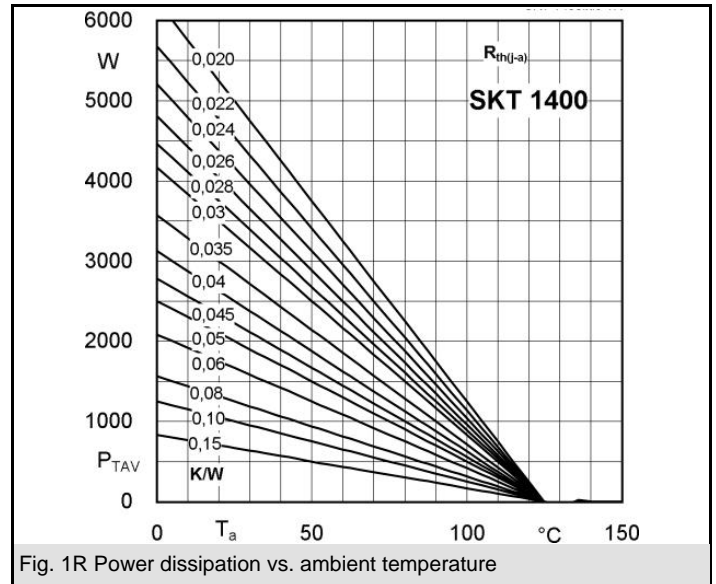
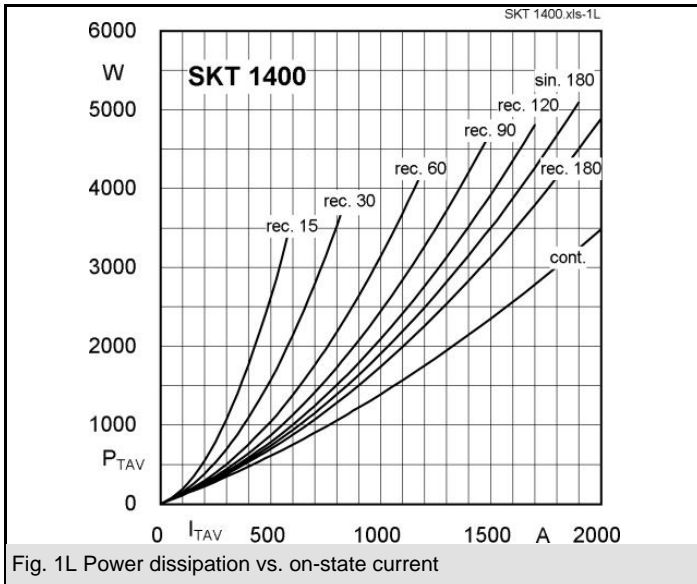

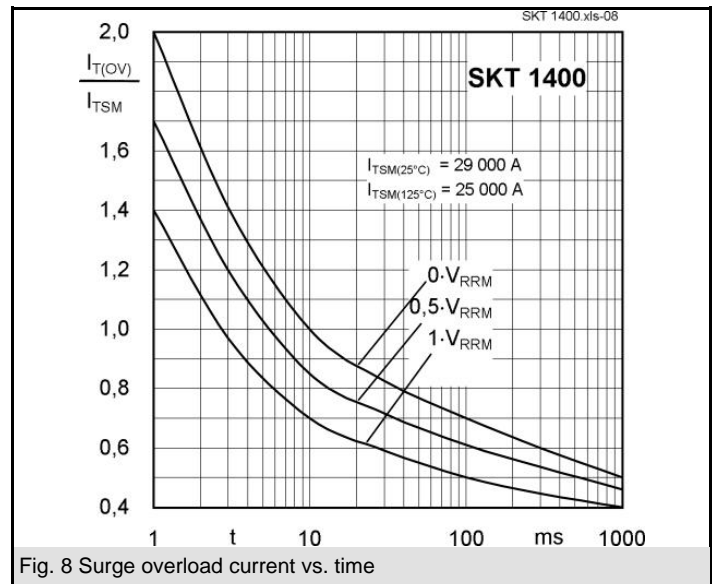
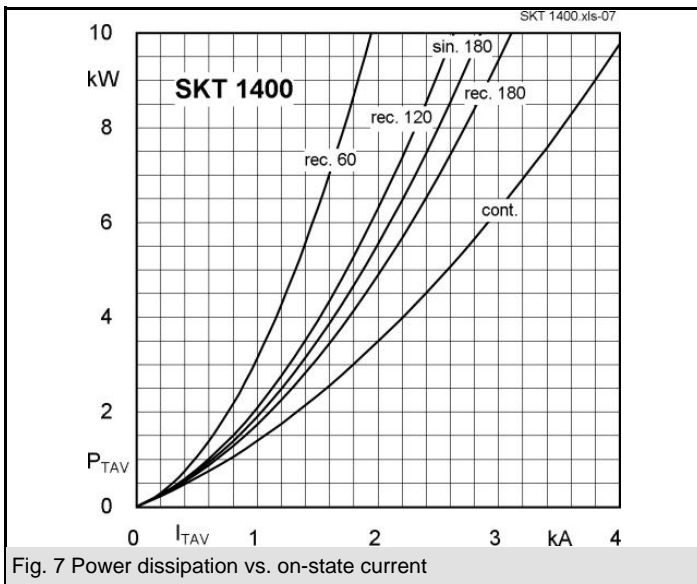
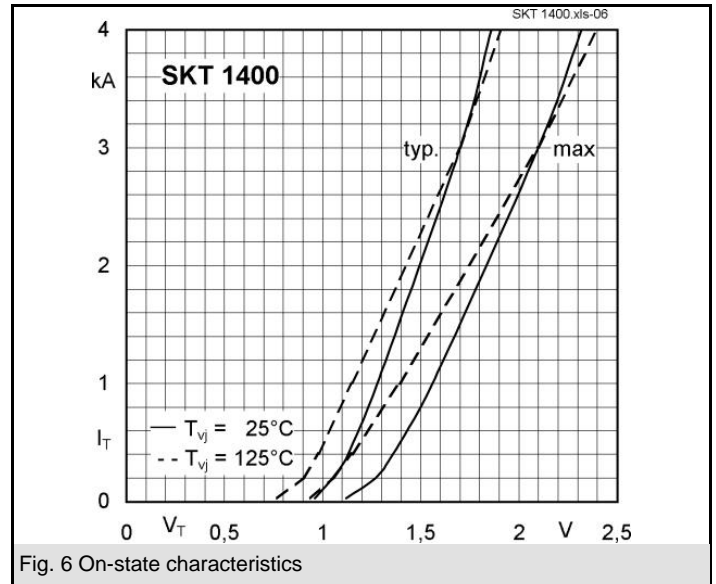
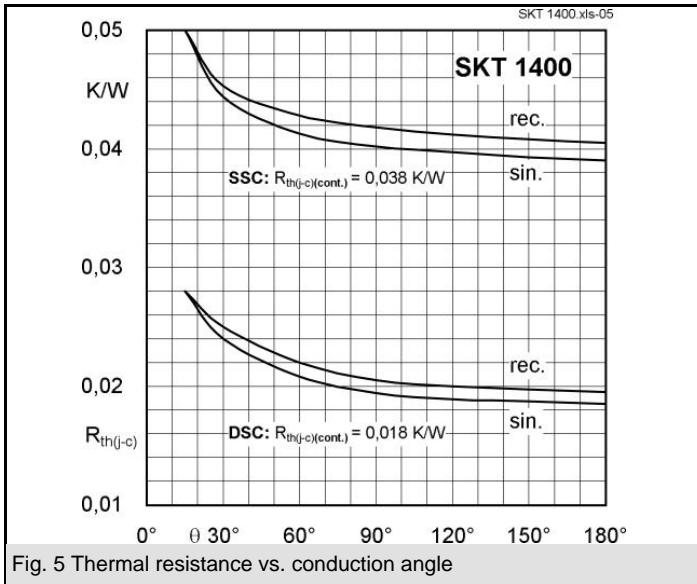

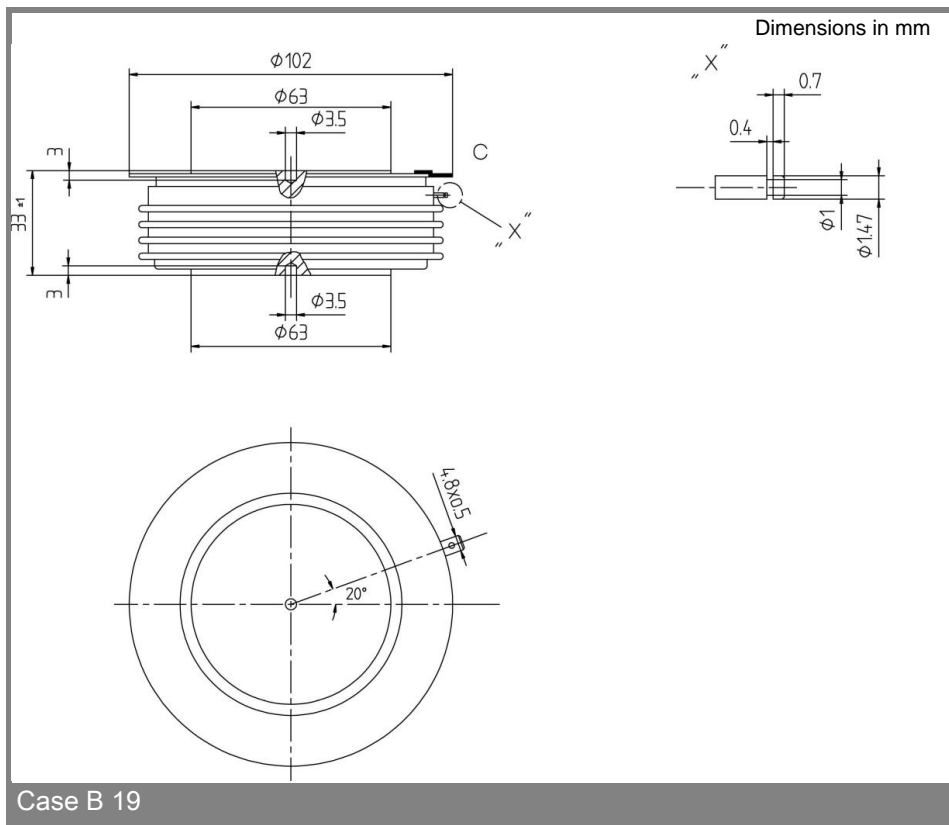
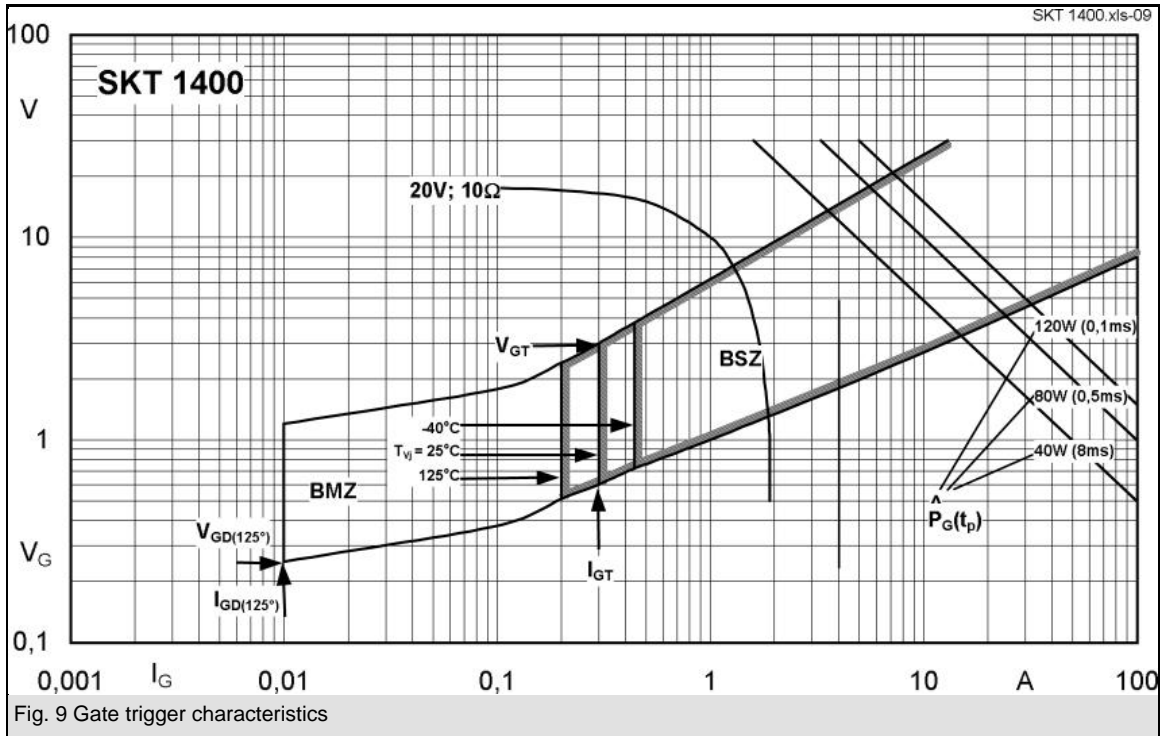

* The specifications of our components may not be considered as an assurance of component characteristics. Components have to be tested for the respective application. Adjustments may be necessary. The use of SEMIKRON products in life support appliances and systems is subject to prior specification and written approval by SEMIKRON. We therefore strongly recommend prior consultation of our personal.