

V <sub>RSM</sub> V <sub>RRM</sub> V	I <sub>FAV</sub> (sin. 180; T <sub>case</sub> = 85 °C)		
	500 A	720 A	1110 A
400	–	<b>SKN 501/04</b>	<b>SKN 870/04</b>
800	–	<b>SKN 501/08</b>	–
1200	–	<b>SKN 501/12</b>	<b>SKN 870/12</b>
1400	–	<b>SKN 501/14</b>	–
1600	–	<b>SKN 501/16</b>	<b>SKN 870/16</b>
1800	<b>SKN 450/18</b>	–	–
2000	<b>SKN 450/20</b>	–	–
2200	<b>SKN 450/22</b>	–	–
2400	<b>SKN 450/24</b>	–	<b>SKN 870/24</b>
2500	<b>SKN 450/25</b>	–	–
3000	–	–	<b>SKN 870/30</b>

## Rectifier Diodes

**SKN 450**  
**SKN 501**  
**SKN 870**

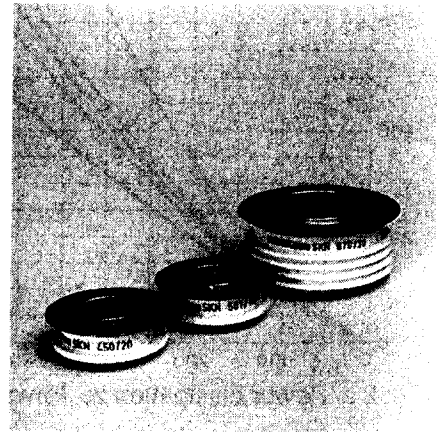

Symbol	Conditions	SKN 450	SKN 501	SKN 870
I <sub>FAV</sub>	sin. 180; DSC; (T <sub>case</sub> = . . .)	450 A (95 °C)	500 A (125 °C)	870 A (105 °C)
I <sub>FSM</sub>	T <sub>vj</sub> = 25 °C; 10 ms	6 000 A	7 000 A	13 000 A
i <sup>2</sup> t	T <sub>vj max.</sub> ; 10 ms	5 000 A	6 000 A	10 500 A
	T <sub>vj</sub> = 25 °C; 8,3 . . . 10 ms	180 000 A <sup>2</sup> s	245 000 A <sup>2</sup> s	850 000 A <sup>2</sup> s
Q <sub>rr</sub>	T <sub>vj</sub> = 140 °C; I <sub>FM</sub> = 500 A;	700 μC	600 μC	2000 μC
	$-\frac{di_F}{dt} = 10 \frac{A}{\mu s}$ typ.	60 A	30 A	100 A
I <sub>RM</sub>	T <sub>vj</sub> = 25 °C; V <sub>R</sub> = V <sub>RRM</sub>	2 mA	2 mA	4 mA
I <sub>R</sub>	T <sub>vj max.</sub> ; V <sub>R</sub> = V <sub>RRM</sub>	20 mA	50 mA	40 mA
V <sub>F</sub>	T <sub>vj</sub> = 25 °C; (I <sub>F</sub> = . . .); max.	1,8 V (1500 A)	1,65 V (1500 A)	1,85 V (3000 A)
V <sub>(TO)</sub>	T <sub>vj max.</sub>	0,85 V	0,80 V	0,85 V
r <sub>T</sub>	T <sub>vj max.</sub>	0,7 mΩ	0,6 mΩ	0,33 mΩ
R <sub>thjc</sub>	DSC/SSC (Double-sided cooling/single sided cooling)	0,075/0,15 °C/W		0,033/ 0,066 °C/W
R <sub>thch</sub>		0,02/0,04 °C/W		0,007/ 0,014 °C/W
T <sub>vj</sub>		– 40 . . . + 150 °C	– 40 . . . + 180 °C	– 40 . . . + 150 °C
T <sub>stg</sub>		– 40 . . . + 150 °C	– 40 . . . + 180 °C	– 40 . . . + 150 °C
F	SI units	4 . . . 5 kN		13,5 . . . 16,5 kN
w	US units	900 . . . 1100 lbs.		3000 . . . 3500 lbs.
	approx.	51 g		230 g
RC	P <sub>R</sub> = 2 W	1 μF + 20 Ω		
R <sub>p</sub>	P <sub>R</sub> = 20 W	25 kΩ		
Case		E 18		E 19

### Features

- Reverse voltages up to 3000 V
- Capsule type metal-ceramic packages with precious metal pressure contacts
- Contact diameters 19 and 32 mm

### Typical Applications

- All-purpose high power rectifier diodes
- SKN 870: High voltage grades available for industrial high power drives and medium traction applications
- Cooling via heatsinks (double or single sided)
- Non-controllable and half-controllable rectifiers
- Free-wheeling diodes

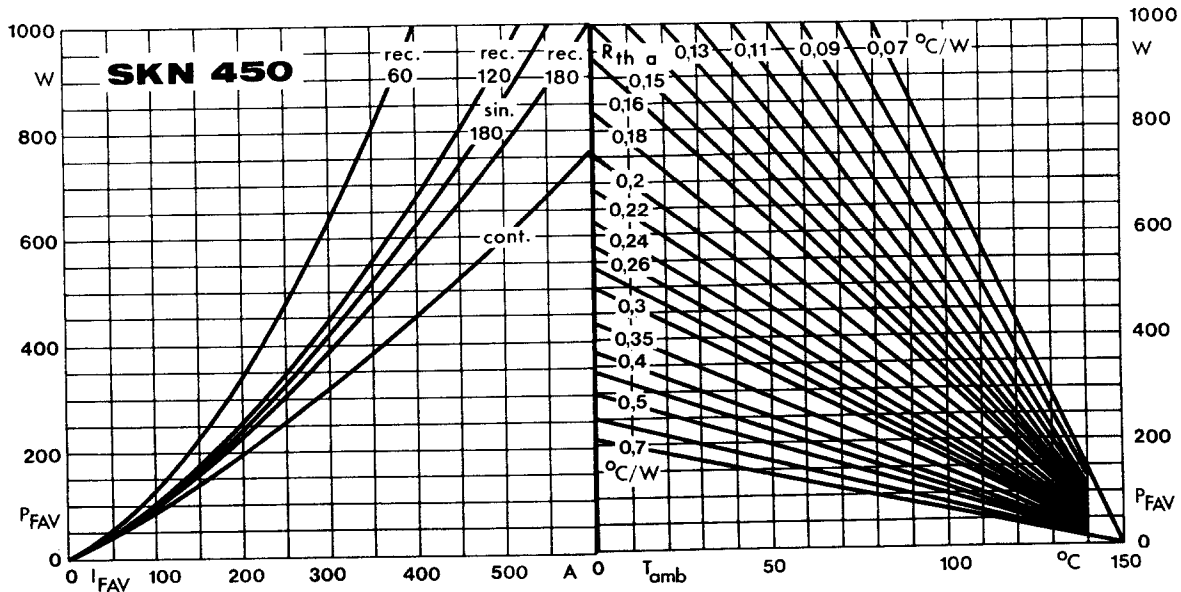

Fig. 2 a Power dissipation vs. forward current and ambient temperature

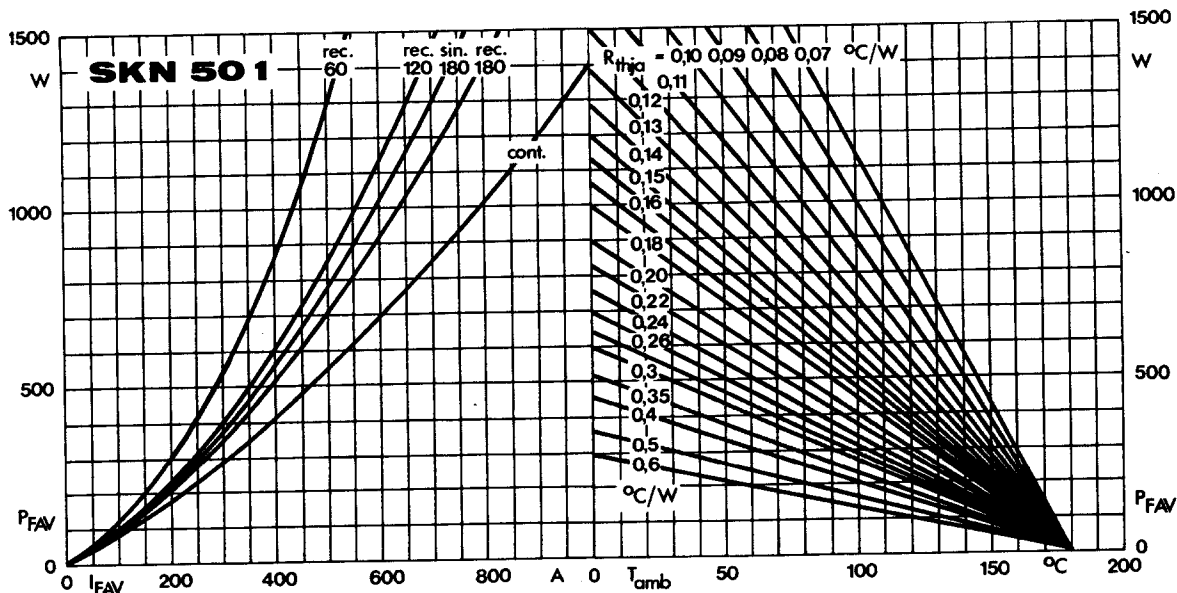

Fig. 2 b Power dissipation vs. forward current and ambient temperature

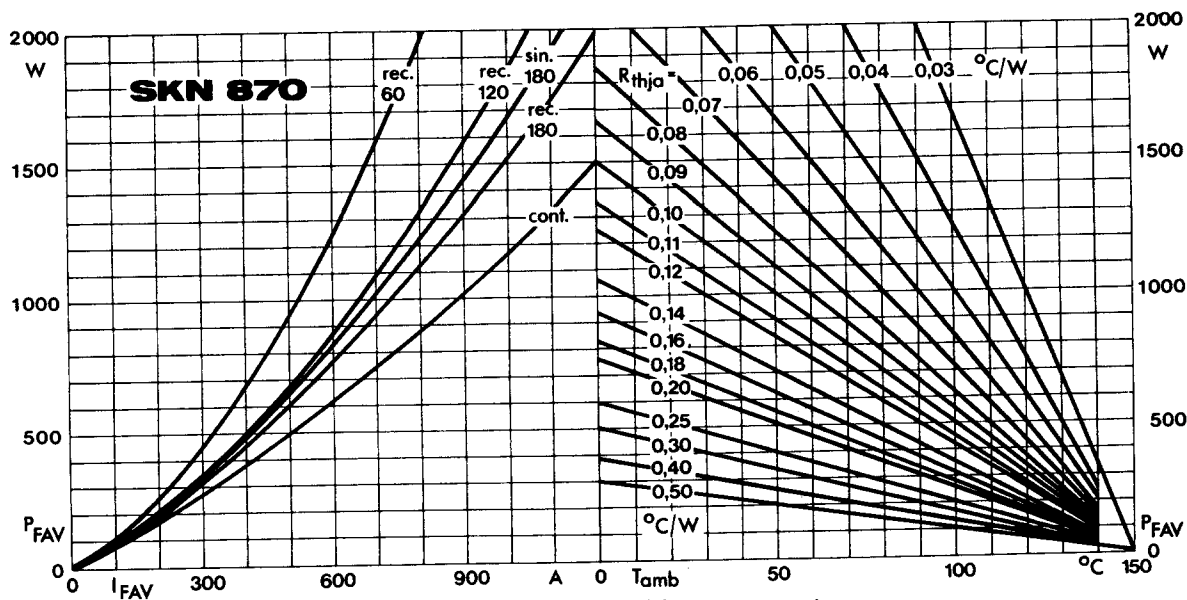

Fig. 2 c Power dissipation vs. forward current and ambient temperature

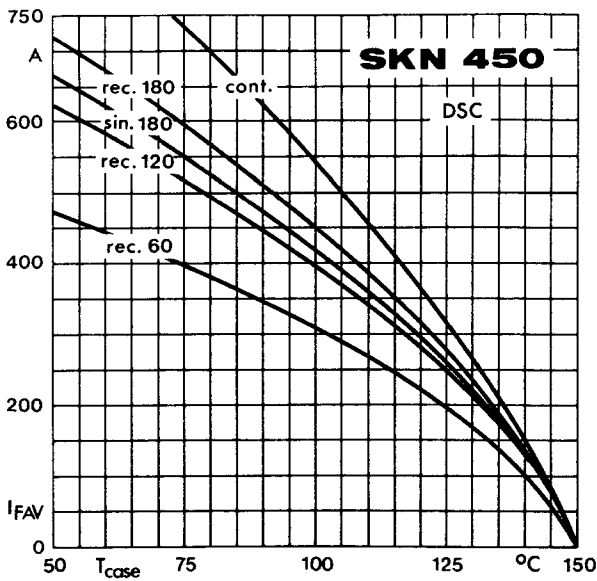

Fig. 3 a Rated forward current vs. case temperature

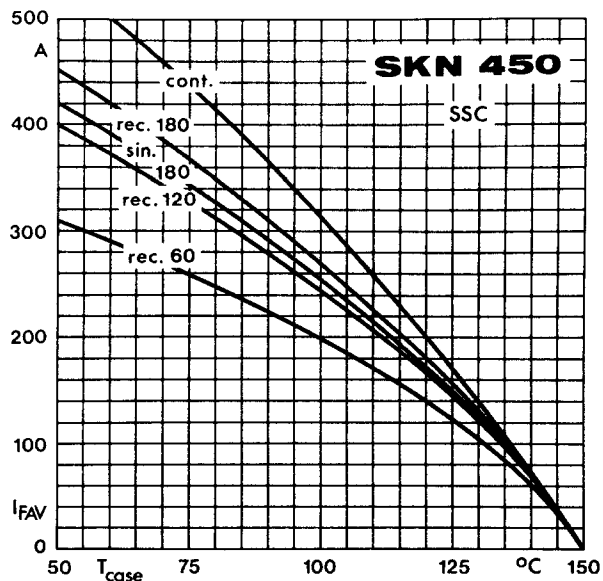

Fig. 3 b Rated forward current vs. case temperature

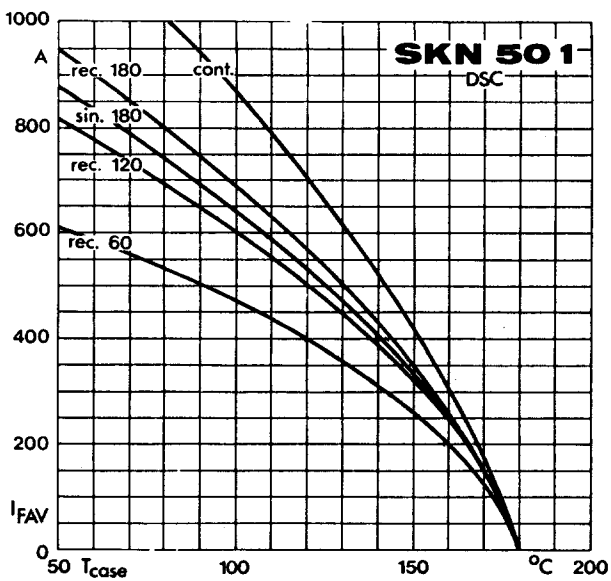

Fig. 3 c Rated forward current vs. case temperature

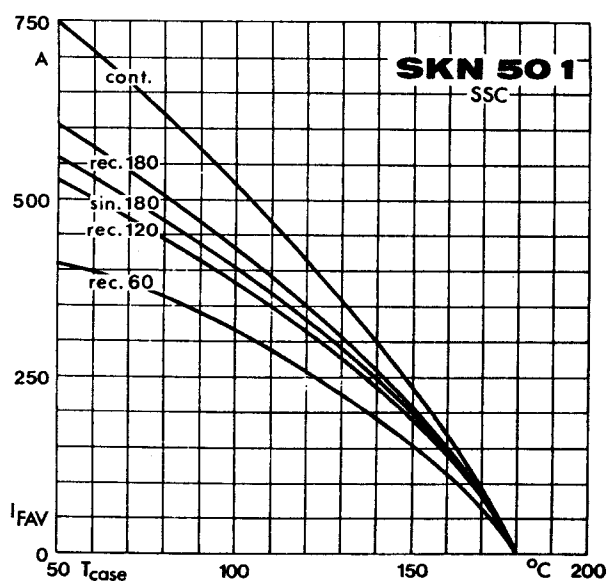

Fig. 3 d Rated forward current vs. case temperature

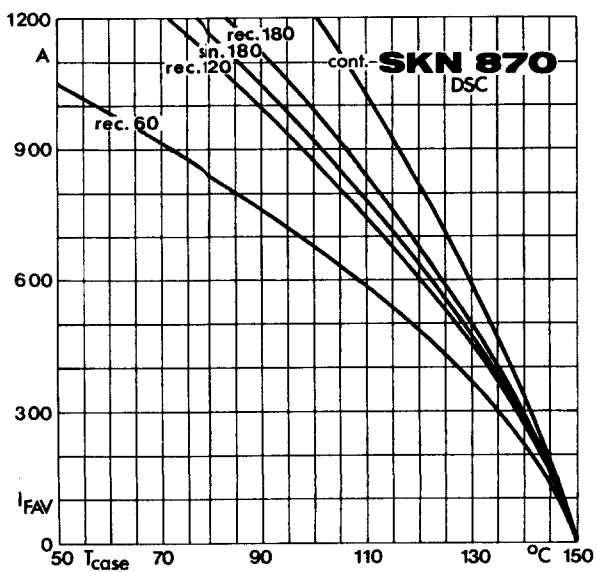

Fig. 3 e Rated forward current vs. case temperature

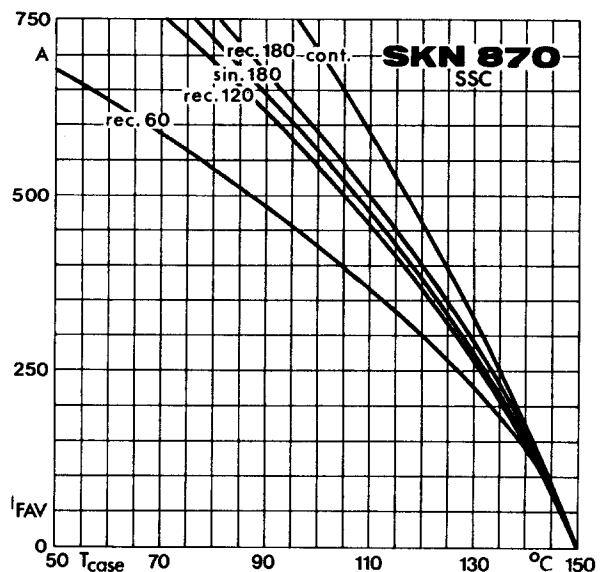

Fig. 3 f Rated forward current vs. case temperature

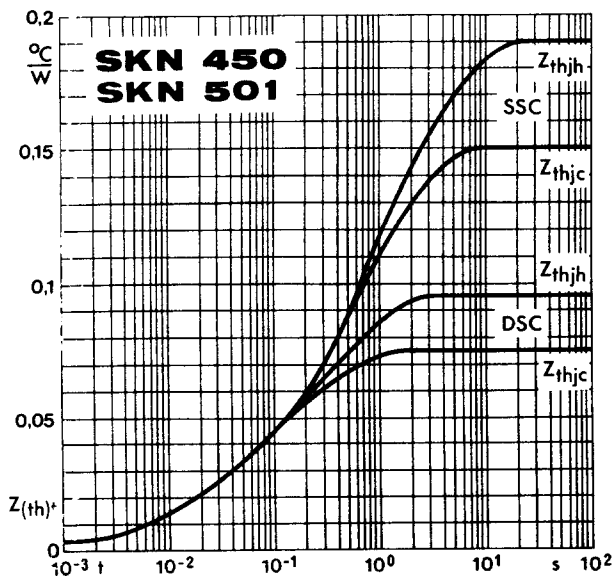

Fig. 5 a Transient thermal impedance vs. time

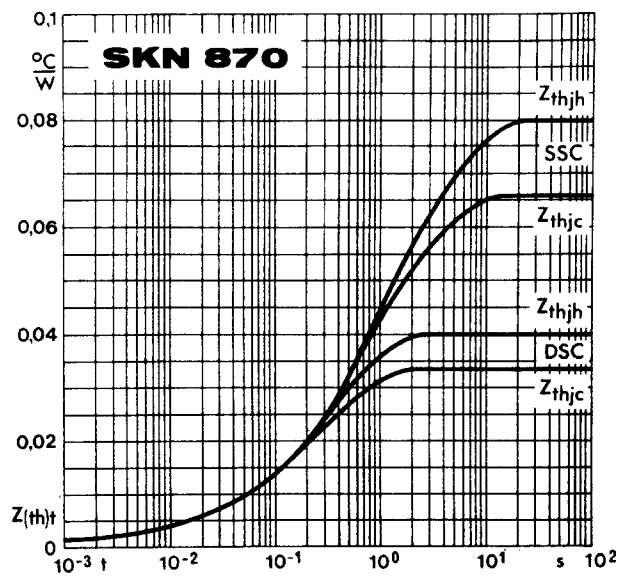

Fig. 5 b Transient thermal impedance vs. time

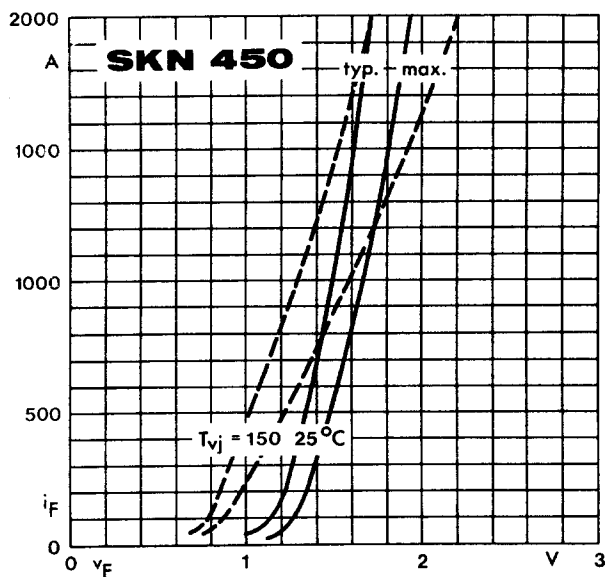

Fig. 6 a Forward characteristics

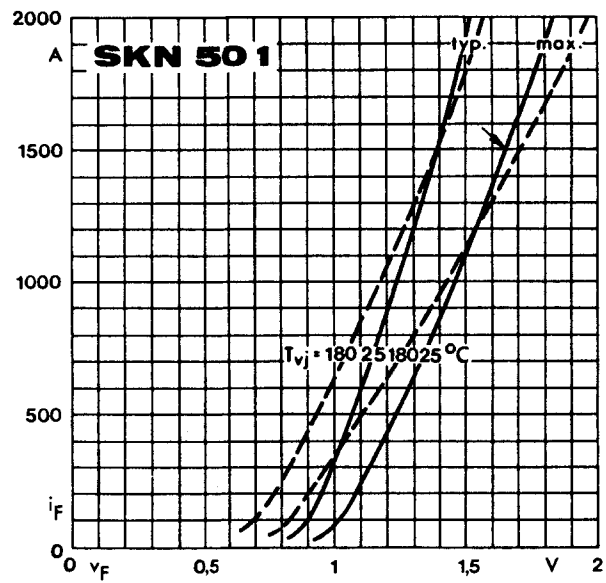

Fig. 6 b Forward characteristics

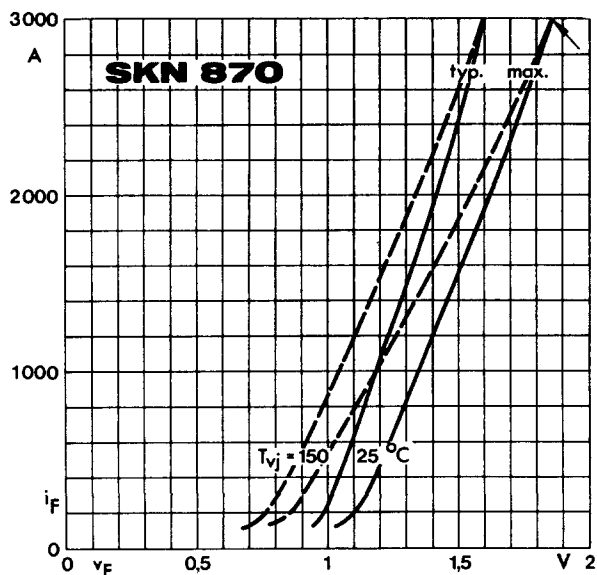

Fig. 6 c Forward characteristics

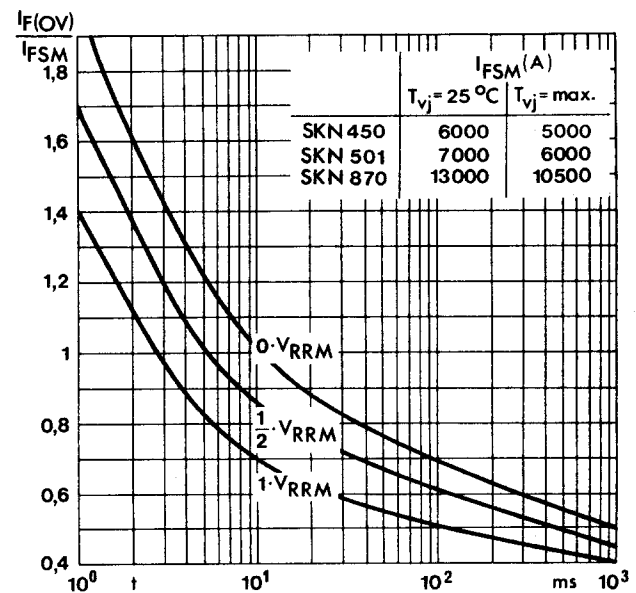

Fig. 7 Surge overload current vs. time

**SKN 320**  
**SKR 320**

Case E 16

IEC: A 22 B

DIN 41 888: 107 B

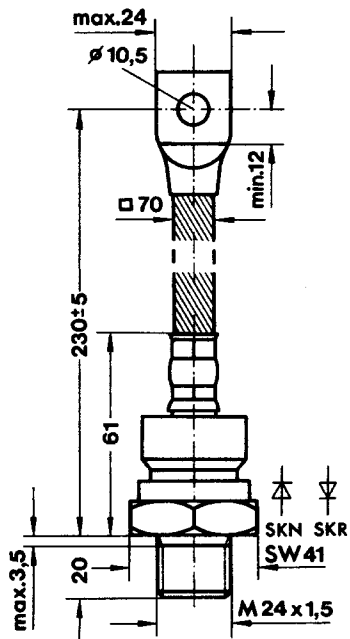

**SKN 400**

Case E 17

IEC: A 22 B

DIN 41 888: 107 B 2

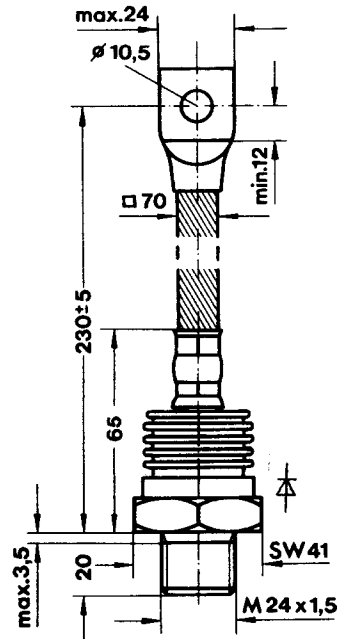

**SKN 450**  
**SKN 501**

Case E 18

DIN 41 814: 151 A 2

JEDEC: DO-200 AA

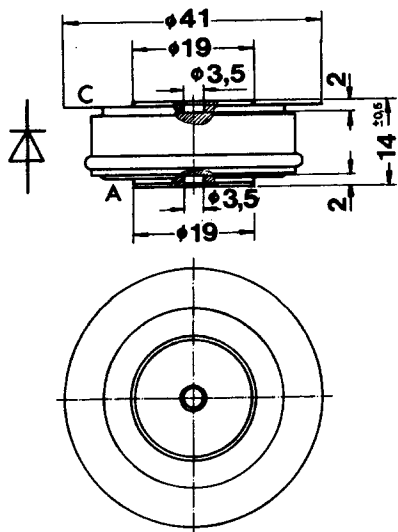

**SKN 870**

Case E 18

DIN 41 814: 153 C 2

JEDEC: DO-200 AB

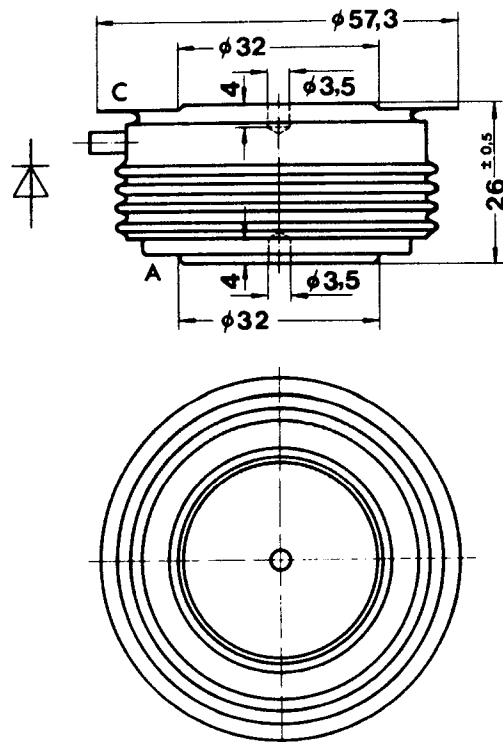

Dimensions in mm