

MG150J7KS60 (600V/150A 7in1)

High Power Switching Applications

Motor Control Applications

- Integrates inverter and brake power circuit into a single package
- The electrodes are isolated from case.
- Low thermal resistance
- $V_{CE(sat)} = 1.6\text{ V (typ.)}$

Equivalent Circuit

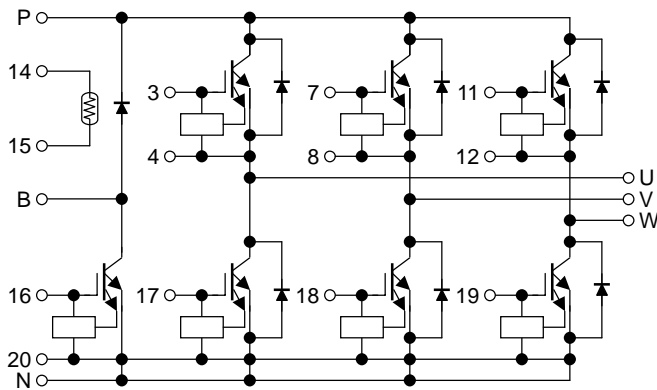

Signal Terminal

1. Open	2. Open	3. G (U)	4. E (U)
5. Open	6. Open	7. G (V)	8. E (V)
9. Open	10. Open	11. G (W)	12. E (W)
13. Open	14. TH1	15. TH2	16. G (B)
17. G (X)	18. G (Y)	19. G (Z)	20. E (L)

Package Dimensions: 2-108G1B

Unit: mm

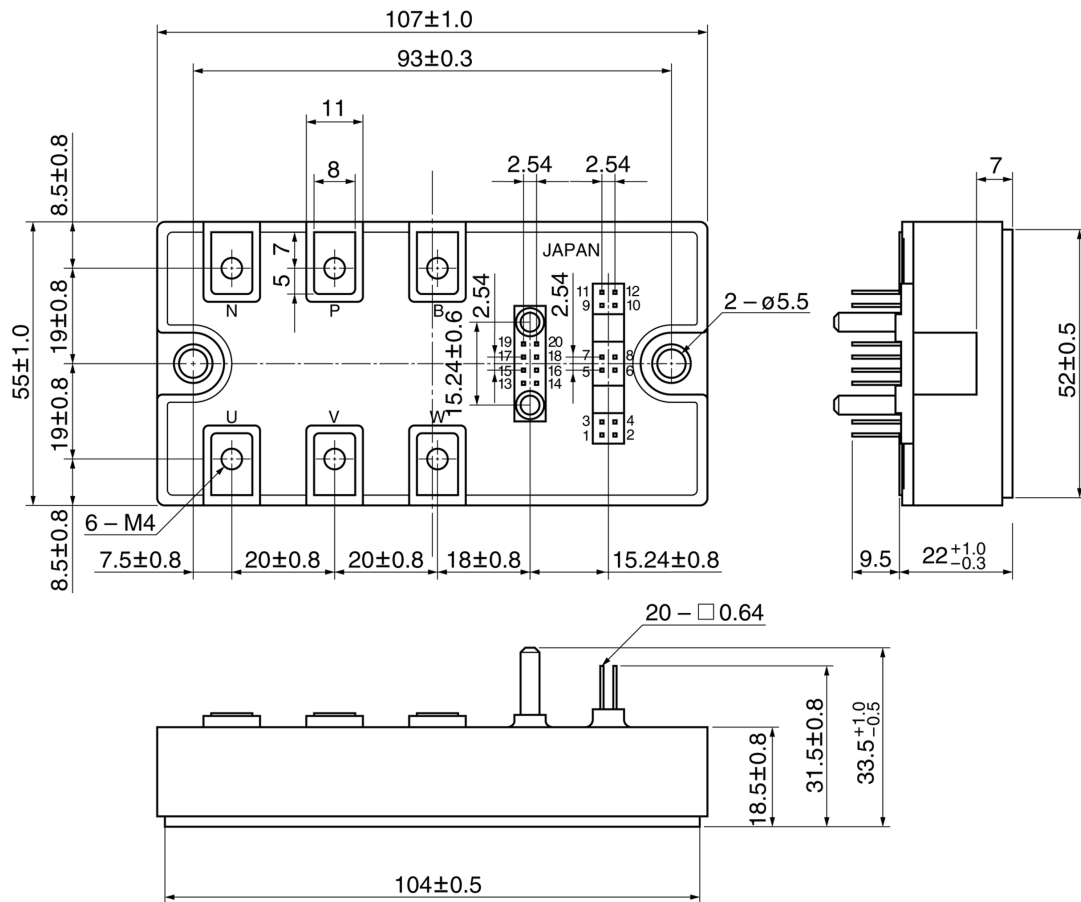

1. Open	2. Open	3. G (U)	4. E (U)
5. Open	6. Open	7. G (V)	8. E (V)
9. Open	10. Open	11. G (W)	12. E (W)
13. Open	14. TH1	15. TH2	16. G (B)
17. G (X)	18. G (Y)	19. G (Z)	20. E (L)

Maximum Ratings (Ta = 25°C)

Stage	Characteristics	Symbol	Rating	Unit	
Inverter	Collector-emitter voltage	V_{CES}	600	V	
	Gate-emitter voltage	V_{GES}	± 20	V	
	Collector current	DC	I_C	150	A
		1 ms	I_{CP}	300	
	Forward current	DC	I_F	150	A
		1 ms	I_{FM}	300	
Collector power dissipation (Tc = 25°C)		P_C	750	W	
Brake	Collector-emitter voltage	V_{CES}	600	V	
	Gate-emitter voltage	V_{GES}	± 20	V	
	Collector current	DC	I_C	75	A
		1 ms	I_{CP}	150	
	Collector power dissipation (Tc = 25°C)		P_C	375	W
	Reverse voltage		V_R	600	V
	Forward current	DC	I_F	75	A
		1 ms	I_{FM}	150	
Module	Junction temperature		T_j	150	°C
	Storage temperature range		T_{stg}	-40~125	°C
	Isolation voltage		V_{isol}	2500 (AC 1 min)	V
	Screw torque	Terminal	—	2 (M4)	N·m
		Mounting	—	3 (M5)	

Electrical Characteristics (Tj = 25°C)

1. Inverter stage

Characteristics	Symbol	Test Condition	Min	Typ.	Max	Unit	
Gate leakage current	I_{GES}	$V_{GE} = \pm 20 \text{ V}, V_{CE} = 0$	—	—	± 500	nA	
Collector cut-off current	I_{CES}	$V_{CE} = 600 \text{ V}, V_{GE} = 0$	—	—	1.0	mA	
Gate-emitter cut-off voltage	$V_{GE (off)}$	$V_{CE} = 5 \text{ V}, I_C = 150 \text{ mA}$	5.0	6.5	8.0	V	
Collector-emitter saturation voltage	$V_{CE (sat)}$	$V_{GE} = 15 \text{ V}, I_C = 150 \text{ A}$	$T_j = 25^\circ\text{C}$	—	1.6	2.2	V
			$T_j = 125^\circ\text{C}$	—	—	2.2	
Input capacitance	C_{ies}	$V_{CE} = 10 \text{ V}, V_{GE} = 0, f = 1 \text{ MHz}$	—	25000	—	pF	
Switching time	Turn-on delay time	$t_{d (on)}$	—	—	1.00	μs	
	Turn-off time	t_{off}	—	—	1.20		
	Fall time	t_f	—	—	0.50		
Reverse recovery time	t_{rr}	—	—	0.30			
Forward voltage	V_F	$I_F = 150 \text{ A}$	—	2.0	2.2	V	

Note 1: Switching time test circuit & timing chart

2. Brake stage

Characteristics	Symbol	Test Condition	Min	Typ.	Max	Unit	
Gate leakage current	I_{GES}	$V_{GE} = \pm 20\text{ V}, V_{CE} = 0$	—	—	± 500	nA	
Collector cut-off current	I_{CES}	$V_{CE} = 600\text{ V}, V_{GE} = 0$	—	—	1.0	mA	
Gate-emitter cut-off voltage	$V_{GE (off)}$	$V_{CE} = 5\text{ V}, I_C = 75\text{ mA}$	5.0	6.5	8.0	V	
Collector-emitter saturation voltage	$V_{CE (sat)}$	$V_{GE} = 15\text{ V}, I_C = 75\text{ A}$	$T_j = 25^\circ\text{C}$	—	1.6	2.2	V
			$T_j = 125^\circ\text{C}$	—	—	2.2	
Input capacitance	C_{ies}	$V_{CE} = 10\text{ V}, V_{GE} = 0, f = 1\text{ MHz}$	—	12000	—	pF	
Switching time	Turn-on delay time	$V_{CC} = 300\text{ V}, I_C = 75\text{ A}$ $V_{GE} = \pm 15\text{ V}, R_G = 24\ \Omega$ (Note 1)	—	—	1.00	μs	
	Turn-off time		—	—	1.20		
	Fall time		—	—	0.50		
Reverse current	I_R	$V_R = 600\text{ V}$	—	—	1.0	mA	
Forward voltage	V_F	$I_F = 75\text{ A}$	—	2.1	2.6	V	

Note 1: Switching time test circuit & timing chart

3. Module ($T_c = 25^\circ\text{C}$)

Characteristics	Symbol	Test Condition	Min	Typ.	Max	Unit
Zero-power resistance	R25	ITM = 0.2 mA	—	100	—	k Ω
B value	B25/85	$T_c = 25^\circ\text{C}/T_c = 85^\circ\text{C}$	—	4390	—	K
Junction to case thermal resistance	$R_{th (j-c)}$	Inverter IGBT stage	—	—	0.167	$^\circ\text{C/W}$
		Inverter FRD stage	—	—	0.313	
		Brake IGBT stage	—	—	0.333	
		Brake FRD stage	—	—	1.000	
Case to fin thermal resistance	$R_{th (c-f)}$	—	—	0.05	—	$^\circ\text{C/W}$

Switching Time Test Circuit & Timing Chart

