

IRK.250, .270, .320 SERIES High Voltage Diode/Diode

FEATURES

- ❖ *High voltage.*
- ❖ *Electrically isolated base plate.*
- ❖ *3000 V_{RMS} isolating voltage.*
- ❖ *Industrial standard package.*
- ❖ *Simplified mechanical designs, rapid assembly.*
- ❖ *High surge capability.*
- ❖ *Large creepage distances.*
- ❖ *Beryllium oxide substrate.*

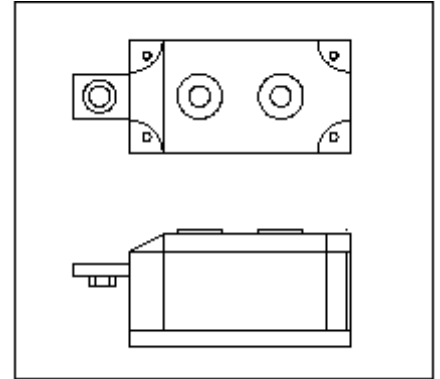

DESCRIPTION

This IRK series of Power Modules uses power diodes in three basic configurations. The semiconductors are electrically isolated from the metal base, allowing common heatsinks and compact assemblies to be built. They can be interconnected to form single phase or three phase bridges. These modules are intended for general purpose applications such as battery chargers, welders and plating equipment.

MAJOR RATINGS & CHARACTERISTICS

Parameters	IRK.250	IRK.270	IRK.320	Units
$I_{F(AV)}$ @ $T_c = 100^\circ\text{C}$	250	270	320	A
$I_{F(RMS)}$	393	424	502	A
I_{FSM} @ 50 Hz	7015	8920	10110	A
I^2t @ 50 Hz	246	398	511	kA^2s
$I^2\sqrt{t}$	2460	3980	5110	$\text{kA}^2\sqrt{\text{s}}$
V_{RRM} range	Up to 1600	Up to 1600	Up to 1600	V
T_J	-40 to 150			$^\circ\text{C}$

POWER MODULES

IRK.250, .270, .320 SERIES

ELECTRICAL SPECIFICATION VOLTAGE RATINGS

Type Number	Voltage Code	V_{RRM} , max. repetitive peak reverse and off-state voltage blocking voltage V	V_{RSM} , max. non-repetitive peak reverse voltage V	I_{RRM} max. @ 150°C mA
	04	400	500	50
IRK.250	06	600	700	50
IRK.270	08	800	900	50
IRK.320	10	1000	1100	50
	12	1200	1300	50
	14	1400	1500	50
	16	1600	1700	50

FORWARD CONDUCTION

	Parameters	IRK.250	IRK.270	IRK.320	Units	Conditions		
$I_{F(AV)}$	Max. average forward current @ case temperature	250	270	320	A	180°C conduction, half sine wave		
		100	100	100	°C			
$I_{F(RMS)}$	Max. RMS forward current	393	424	502	A	as AC switch		
I_{FSM}	Max. peak, one cycle forward non-repetitive surge current	7015	8920	10110	A	t = 10ms	No voltage reappplied	Sinusoidal half wave, Initial $T_J = T_J$ max.
		5900	7500	8500	A	t = 10ms	100% V_{RRM} reappplied	
I^2t	Maximum I^2t for fusing	246	398	511	kA ² s	t = 10ms	No voltage reappplied	Sinusoidal half wave, Initial $T_J = T_J$ max.
		174	281	361	kA ² s	t = 10ms	100% V_{RRM} reappplied	
$I^2\sqrt{t}$	Maximum $I^2\sqrt{t}$ for fusing	2460	3980	5110	kA ² √s	t = 0.1 to 10ms. No voltage reappplied.		
$V_{F(TO)1}$	Low level value of threshold voltage	0.79	0.74	0.69	V	$(16.7\% \times \pi \times I_{F(AV)} < I < \pi \times I_{F(AV)})$, $T_J = T_J$ max.		
$V_{F(TO)2}$	High level value of threshold voltage	0.92	0.87	0.86	V	$(\pi \times I_{F(AV)} < I < 20 \times \pi \times I_{F(AV)})$, $T_J = T_J$ max.		
r_{11}	Low level forward slope resistance	0.63	0.94	0.59	mΩ	$(16.7\% \times \pi \times I_{F(AV)} < I < \pi \times I_{F(AV)})$, $T_J = T_J$ max.		
r_{12}	High level forward slope resistance	0.49	0.81	0.44	mΩ	$(\pi \times I_{F(AV)} < I < 20 \times \pi \times I_{F(AV)})$, $T_J = T_J$ max.		
V_{FM}	Max. forward voltage drop	1.29	1.48	1.28	V	$I_{FM} = \pi \times I_{F(AV)}$, $T_J = T_J$ max., 180° conduction AV. power = $V_{F(TO)} \times I_{F(AV)} + r_1 \times (I_{F(RMS)})^2$		

POWER MODULES

IRK.250, .270, .320SERIES

THERMAL AND MECHANICAL SPECIFICATIONS

	Parameters	IRK.250	IRK.270	IRK.320	Units	Conditions
T_J	Junction operating temperature	-40 to 150			°C	
T_{stg}	Storage temperature range	-40 to 150			°C	
R_{thj-c}	Max. internal thermal resistance, junction to case	0.16	0.125	0.125	K/W	IRKD../IRKJ../IRKC.. Per junction, DC operation
R_{thC-S}	Thermal resistance, case to heatsink	0.035	0.035	0.035	K/W	Mounting surface flat, smooth and greased
T	Mounting torque $\pm 10\%$	4 to 6			Nm	A mounting compound is recommended and the torque should be rechecked after a period of about 3 hours to allow for the spread of the compound.
	Module to heatsink					
	Busbar to module	8 to 10			Nm	
Wt	Approximate weight	800			g	

BLOCKING

	Parameter	IRK.250	IRK.270	IRK.320	Units	Conditions
I_{RFM}	Max. peak reverse leakage current	50	50	50	mA	$T_J = 150^\circ\text{C}$
V_{INS}	RMS isolation voltage	3000	3000	3000	V	50 Hz, circuit to base, all terminals shorted, $t=1\text{sec}$

OUTLINE DIAGRAM

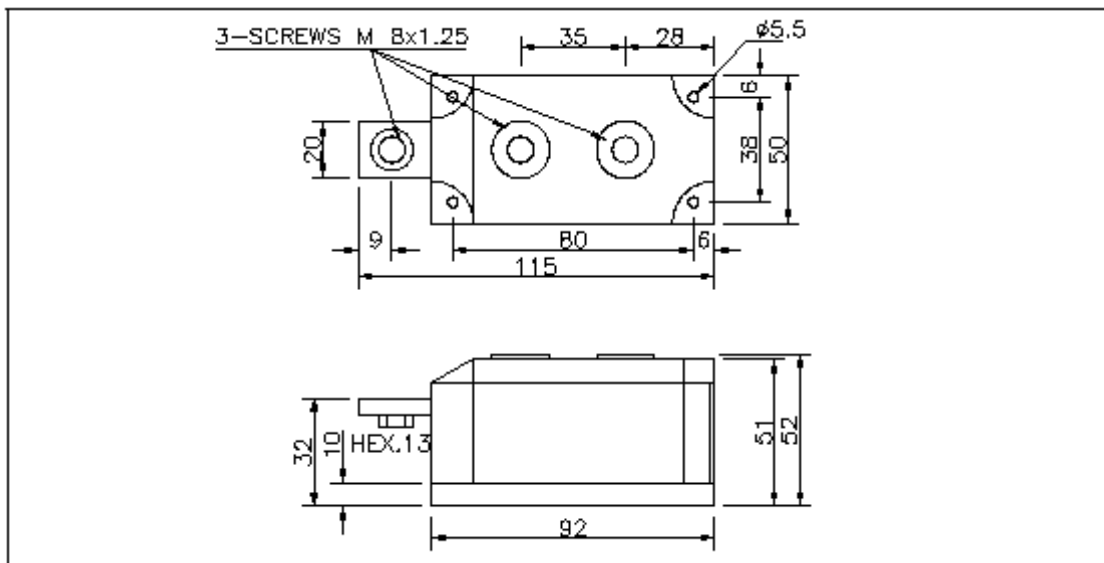

POWER MODULES

IRK.250, .270, .320 Series

Circuit Configuration Table

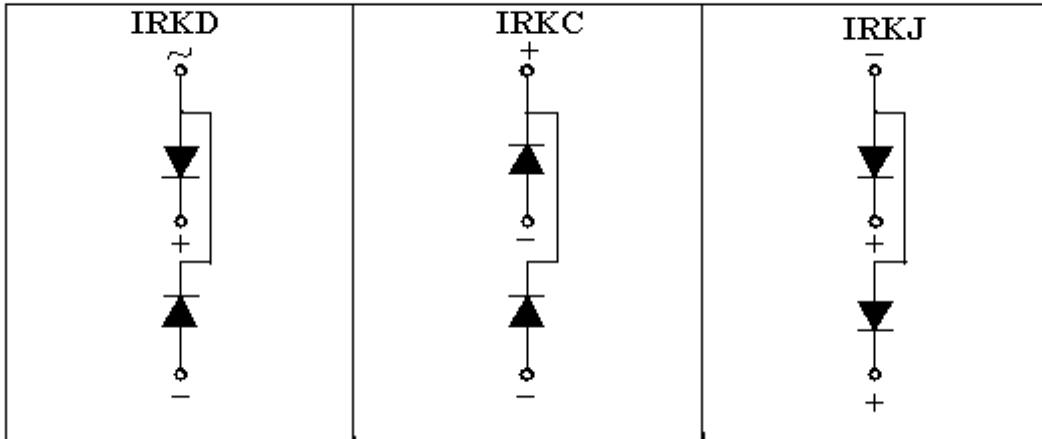

Ordering Information Table

