

$V_{CE} = 1200\text{ V}$

$I_C = 100\text{ A}$

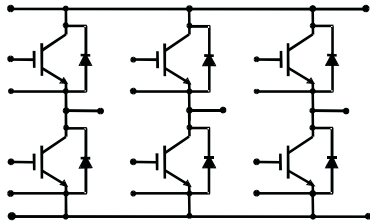

IGBT Module LoPak3 SPT

5SNS 0100W120100

PRELIMINARY

Doc. No. 5SYA1522-01 May. 01

- Low-loss, rugged IGBT SPT chip-set
- EMC friendly diode with positive temp. coefficient of on-state
- Low profile compact baseless package
- Industry standard package
- UL File no. E63532



Maximum Rated Values

($T_{vj} = 25^\circ\text{C}$, unless specified otherwise)

Parameter	Symbol	Conditions	Values	Unit
Collector-Emitter Voltage	V_{CES}	V_{GE} shorted	1200	V
DC Collector Current	I_C	$T_{hs} = 70^\circ\text{C}$	100	A
Peak Collector Current	I_{CM}	Pulse: $t_p = 1\text{ms}$, $T_{hs} = 70^\circ\text{C}$	200	A
Gate Emitter Voltage	V_{GES}		± 20	V
Total Power Dissipation	P_{tot}	$T_{hs} = 25^\circ\text{C}$ per switch	450	W
IGBT Switching SOA	SwSOA	$I_C = 200\text{ A}$, $V_{CEM} = 1200\text{ V}$, $V_{CC} \leq 1000\text{ V}$, $V_{GE} = \pm 15\text{ V}$, $T_{vj} = 125^\circ\text{C}$ voltages measured on auxiliary terminals		
IGBT Short Circuit SOA	SCSOA	$V_{CC} = 900\text{ V}$, $V_{CEM} = 1200\text{ V}$, $t_p = 10\ \mu\text{s}$, $V_{GE} = \pm 15\text{ V}$, $T_{vj} = 125^\circ\text{C}$		
DC Forward Current	I_F		100	A
Peak Forward Current	I_{FM}	Pulse: $t_p = 1\text{ms}$, $T_{hs} = 70^\circ\text{C}$	200	A

ABB Semiconductors AG reserves the right to change specifications without notice.



Maximum Rated Values (cont.) ($T_{vj} = 25^{\circ}\text{C}$, unless specified otherwise)

Parameter	Symbol	Conditions	Values	Unit
Junction Temperature	T_{vj}		- 40 ~ 150	$^{\circ}\text{C}$
Storage Temperature	T_{tstg}/T_{cop}		- 40 ~ 125	$^{\circ}\text{C}$
Isolation Voltage	V_{iso}	1 min, $f = 50\text{Hz}$	2500	V
Mounting	Base to Heatsink	(M5) Hole 5.5mm diameter	3 ~ 6	Nm
	Main Terminals	Pin: 1.15*1.0 mm		
	PCB mounting	Pitch of pins : 3.81 mm		
	Gate, Emitter Aux.	Pin: 1.15*1.0 mm		

IGBT Characteristic Values ($T_{vj} = 25^{\circ}\text{C}$, unless specified otherwise)

Parameter	Symbol	Conditions	min.	typ.	max.	Unit	
Collector-Emitter Saturation Voltage	$V_{CE(sat)}$ *	$I_C = 100\text{ A}$, $V_{GE} = 15\text{ V}$	$T_{vj} = 25^{\circ}\text{C}$	2.00	2.35	V	
			$T_{vj} = 125^{\circ}\text{C}$	2.20		V	
Collector Cut-off Current	I_{CES}	$V_{CE} = 1200\text{ V}$, $V_{GE} = 0\text{ V}$, $T_{vj} = 125^{\circ}\text{C}$			8	mA	
Gate-Emitter leakage Current	I_{GES}	$V_{CE} = 0\text{ V}$, $V_{GE} = \pm 20\text{ V}$, $T_{vj} = 125^{\circ}\text{C}$			± 500	nA	
Gate-Emitter Threshold Voltage	$V_{GE(TO)}$	$I_C = 4\text{ mA}$, $V_{CE} = V_{GE}$	4.5		6.5	V	
Total Gate Charge	Q_{ge}	$I_C = 100\text{ A}$, $V_{CE} = 600\text{ V}$, $V_{GE} = -15\text{ to }15\text{ V}$		1000		nC	
Input Capacitance	C_{ies}	$V_{CE} = 25\text{ V}$, $V_{GE} = 0\text{ V}$, $f = 1\text{MHz}$		9.0		nF	
Output Capacitance	C_{oes}				2.2		nF
Reverse Transfer Capacitance	C_{res}				1.8		nF
Turn-On Delay Time	$t_{d(on)}$	$I_C = 100\text{ A}$, $V_{CC} = 600\text{ V}$, $R_{gon} = 10\ \Omega$, $T_{vj} = 125^{\circ}\text{C}$, $V_{GE} = \pm 15\text{ V}$		0.08		μs	
Rise Time	t_r				0.06		μs
Turn-Off Delay Time	$t_{d(off)}$	$I_C = 100\text{ A}$, $V_{CC} = 600\text{ V}$, $R_{goff} = 10\ \Omega$, $T_{vj} = 125^{\circ}\text{C}$, $V_{GE} = \pm 15\text{ V}$		0.5		μs	
Fall Time	t_f				0.09		μs
Turn-on Switching Energy	E_{on}	$R_{gon} = 10\ \Omega$, $I_C = 100\text{ A}$, $T_{vj} = 125^{\circ}\text{C}$, $V_{CC} = 600\text{ V}$, $V_{GE} = \pm 15\text{ V}$, inductive load, integrated up to: 3% V_{CE} (E_{on}), 1% I_C (E_{off})		11.0		mJ	
Turn-off Switching Energy	E_{off}		$R_{goff} = 10\ \Omega$		9.5		mJ
Module stray Inductance Plus to Minus	$L_{s\ DC}$				25	nH	
Resistance terminal-chip	$R_{CC'+EE'}$		$T_{hs} = 25^{\circ}\text{C}$	1.25		m Ω	
			$T_{hs} = 125^{\circ}\text{C}$	1.90			

* Note 1: Collector emitter saturation voltage is given at die level.

Diode Characteristic Values(T_{vj} = 25°C, unless specified otherwise)

Parameter	Symbol	Conditions	min.	typ.	max.	Unit
Forward Voltage	V _F *	I _F = 100 A	T _{vj} = 25 °C	2.00	2.40	V
			T _{vj} = 125 °C	2.00		
Reverse Recovery Current	I _{rrm}	I _F = 100 A, R _{gon} = 10 Ω, V _{CC} = 600 V, V _{GE} = ±15 V, T _{vj} = 125 °C		120		A
Reverse Recovery Charge	Q _{rr}			20		μC
Reverse Recovery Time	t _{rr}			0.30		μs
Reverse Recovery Energy	E _{rec}	I _F = 100 A, T _{vj} = 125 °C, V _{CC} = 600V, R _{gon} = 10 Ω, V _{GE} = ±15 V, inductive load, fully integrated		8.5		mJ
Resistance terminal-chip	R _{CC'+EE'}		T _{hs} = 25 °C	1.25		mΩ
			T _{hs} = 125 °C	1.90		

* Note 2: Forward voltage is given at die level

Thermal Characteristics(T_j = 25°C, unless specified otherwise)

Parameter	Symbol	Conditions	min.	typ.	max.	Unit
IGBT Thermal Resistance Junction to Heatsink	R _{th j-h Igbt}	Heatsink: flatness < +/- 20 μm, roughness < 6 μm without ridge Thermal grease: thickness: 30 μm < t < 50 μm			0.280	°C/W
Diode Thermal Resistance Junction to Heatsink	R _{th j-h Diode}				0.560	°C/W
Equivalent IGBT Thermal Resistance Junct. to Case	R _{th j-c Igbt}				0.180	°C/W
Equivalent Diode Thermal Resistance Junct. to Case	R _{th j-c Diode}				0.360	°C/W

Mechanical Properties

Parameter	Symbol	Conditions	min.	typ.	max.	Unit
Dimensions	L*W*H	Typical , see outline drawing	121.5 * 61.5 * 20.5			mm
Clearance Distance	D _C	acc. IEC 664-1 and prEN50124-1:1995	Term. to base:	8.5		mm
			Term. to term:	9.5		mm
Surface Creepage Distance	D _{sc}	acc. IEC 664-1 and prEN50124-1:1995	Term. to base:	12.5		mm
			Term. to term:	15.5		mm
Weight				215		gr

Electrical configuration

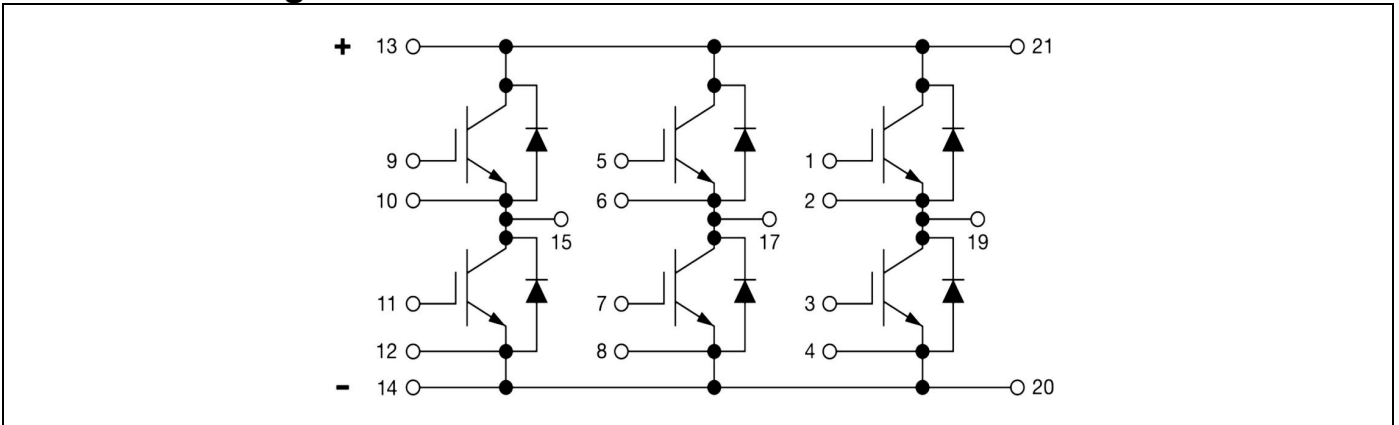

Outline drawing

