

Features

- Gen. 4 Ultrafast Speed IGBT Technology
- HEXFRED™ Diode with UltraSoft Reverse Recovery
- Very Low Conduction and Switching Losses
- Optional SMT Thermistor (NTC)
- Aluminum Nitride DBC
- Very Low Stray Inductance Design for High Speed Operation
- UL approved (file E78996)

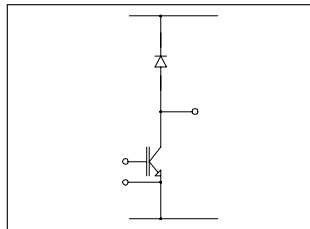

$V_{CES} = 600V$
 $I_C = 100A,$
 $T_C = 25^{\circ}C$

Benefits

- Optimized for Welding, UPS and SMPS Applications
- Operating Frequencies > 20 kHz Hard Switching, >200 kHz Resonant Mode
- Low EMI, requires Less Snubbing
- Direct Mounting to Heatsink
- PCB Solderable Terminals
- Very Low Junction-to-Case Thermal Resistance

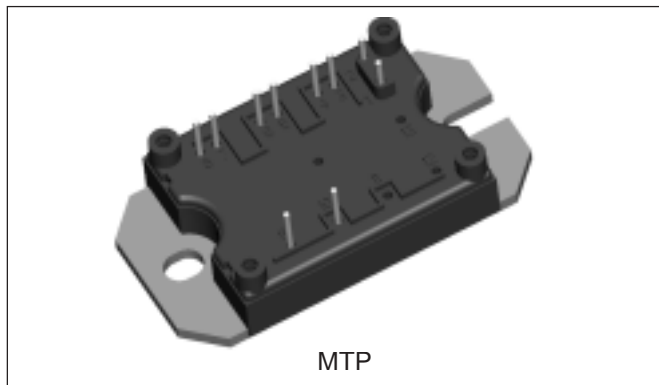

Absolute Maximum Ratings

Parameters		Max	Units
V_{CES}	Collector-to-Emitter Voltage	600	V
I_C	Continuous Collector Current	@ $T_C = 25^{\circ}C$	100
		@ $T_C = 122^{\circ}C$	50
I_{CM}	Pulsed Collector Current	200	
I_{LM}	Peak Switching Current	200	
I_F	Diode Continuous Forward Current	@ $T_C = 100^{\circ}C$	48
I_{FM}	Peak Diode Forward Current	200	
V_{GE}	Gate-to-Emitter Voltage	± 20	V
V_{ISOL}	RMS Isolation Voltage, Any Terminal to Case, $t = 1$ min	2500	
P_D	Maximum Power Dissipation	IGBT @ $T_C = 25^{\circ}C$	445
		@ $T_C = 100^{\circ}C$	175
		Diode @ $T_C = 25^{\circ}C$	205
		@ $T_C = 100^{\circ}C$	83

Electrical Characteristics @ T_J = 25°C (unless otherwise specified)

Parameters		Min	Typ	Max	Units	Test Conditions
V _{(BR)CES}	Collector-to-Emitter Breakdown Voltage	600			V	V _{GE} = 0V, I _C = 250μA
V _{CE(on)}	Collector-to-Emitter Voltage		1.69	2.31		V _{GE} = 15V, I _C = 50A
			1.96	2.55		V _{GE} = 15V, I _C = 100A
			1.88	2.24		V _{GE} = 15V, I _C = 100A, T _J = 150°C
V _{GE(th)}	Gate Threshold Voltage	3		6	I _C = 0.5mA	
B _{VR}	Diode Reverse Breakdown Voltage	600			I _R = 200μA	
ΔV _{GE(th)} /ΔT _J	Temperature Coeff. of Threshold Voltage		- 13		mV/°C	V _{CE} = V _{GE} , I _C = 500μA
g _{fe}	Forward Transconductance	22	29		S	V _{CE} = 50V, I _C = 100A
I _{CES}	Collector-to-Emitter Leaking Current			0.25	mA	V _{GE} = 0V, V _{CE} = 600V
				6		V _{GE} = 0V, V _{CE} = 600V, T _J = 150°C
V _{FM}	Diode Forward Voltage Drop		1.64	1.82	V	I _F = 100A, V _{GE} = 0V
			1.56	1.74		I _F = 100A, V _{GE} = 0V, T _J = 150°C
I _{GES}	Gate-to-Emitter Leakage Current			± 250	nA	V _{GE} = ± 20V

Switching Characteristics @ T_J = 25°C (unless otherwise specified)

Parameters		Min	Typ	Max	Units	Test Conditions
Q _g	Total Gate Charge (turn-on)		370	555	nC	I _C = 100A V _{CC} = 480V V _{GE} = 15V
Q _{ge}	Gate-Emitter Charge (turn-on)		64	96		
Q _{gc}	Gate-Collector Charge (turn-on)		163	245		
E _{on}	Turn-On Switching Loss		0.7	1.2	mJ	I _C = 50A, V _{CC} = 480V, V _{GE} = 15V, R _g = 5Ω
E _{off}	Turn-Off Switching Loss		1.7	2.6		
E _{ts}	Total Switching Loss		2.4	3.8		
E _{on}	Turn-On Switching Loss		1.1	1.7	mJ	I _C = 50A, V _{CC} = 480V, V _{GE} = 15V R _g = 5Ω, T _J = 125°C
E _{off}	Turn-Off Switching Loss		2.5	3.8		
E _{ts}	Total Switching Loss		3.6	5.5		
C _{ies}	Input Capacitance		9800	14700	pF	V _{GE} = 0V V _{CC} = 30V f = 1.0 MHz
C _{oes}	Output Capacitance		602	903		
C _{res}	Reverse Transfer Capacitance		121	182		
C _t	Diode Junction Capacitance		118	177		
t _{rr}	Diode Reverse Recovery Time		99	150	ns	V _{CC} = 480V, I _C = 50A
I _{rr}	Diode Peak Reverse Current		6.5	9.8	A	di/dt = 200A/μs
Q _{rr}	Diode Recovery Charge		320	735	nC	R _g = 5Ω
di _(rec) /dt	Diode Peak Rate of Fall of Recovery During t _b		236		A/μs	

Thermistor Specifications (50MT060ULST only)

Parameters	Min	Typ	Max	Units	Test Conditions
R ₀ ⁽¹⁾ Resistance		30		kΩ	T ₀ = 25°C
β ⁽¹⁾⁽²⁾ Sensitivity index of the thermistor material		4000		K	T ₀ = 25°C T ₁ = 85°C

(1) T₀, T₁ are thermistor's temperatures

$$(2) \frac{R_0}{R_1} = \exp \left[\beta \left(\frac{1}{T_0} - \frac{1}{T_1} \right) \right], \text{ Temperatures in kelvin}$$

Thermal- Mechanical Specifications

Parameters	Min	Typ	Max	Units
T _J Operating Junction Temperature Range	- 40		150	°C
T _{STG} Storage Temperature Range	- 40		125	
R _{thJC} Junction-to-Case	IGBT	0.18	0.28	°C/ W
	Diode	0.4	0.6	
R _{thCS} Case-to-Sink (Heatsink Compound Thermal Conductivity = 1 W/mK)	Module	0.06		
T Mounting torque to heatsink (3)		3 ± 10%		Nm
Wt Weight		66		g

(3) A mounting compound is recommended and the torque should be checked after 3 hours to allow for the spread of the compound. Lubricated threads

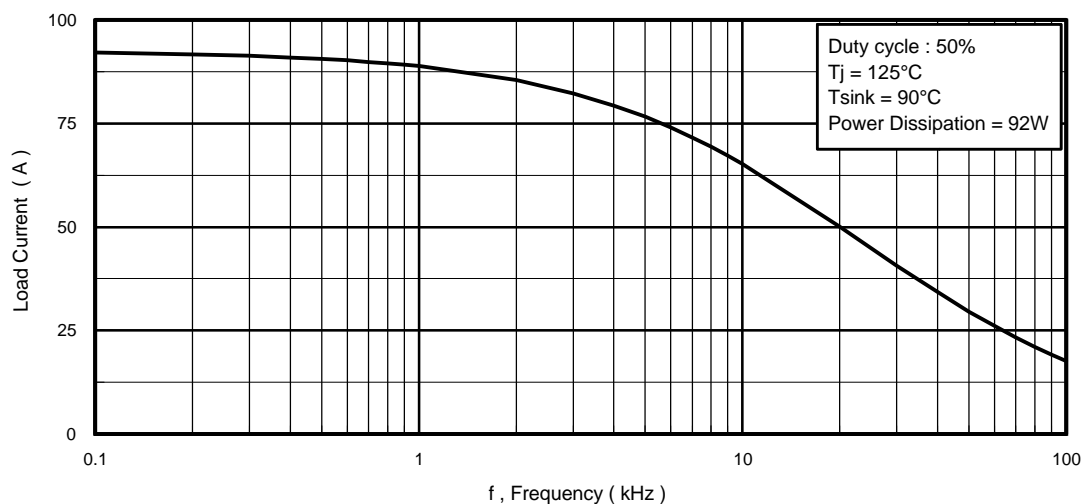
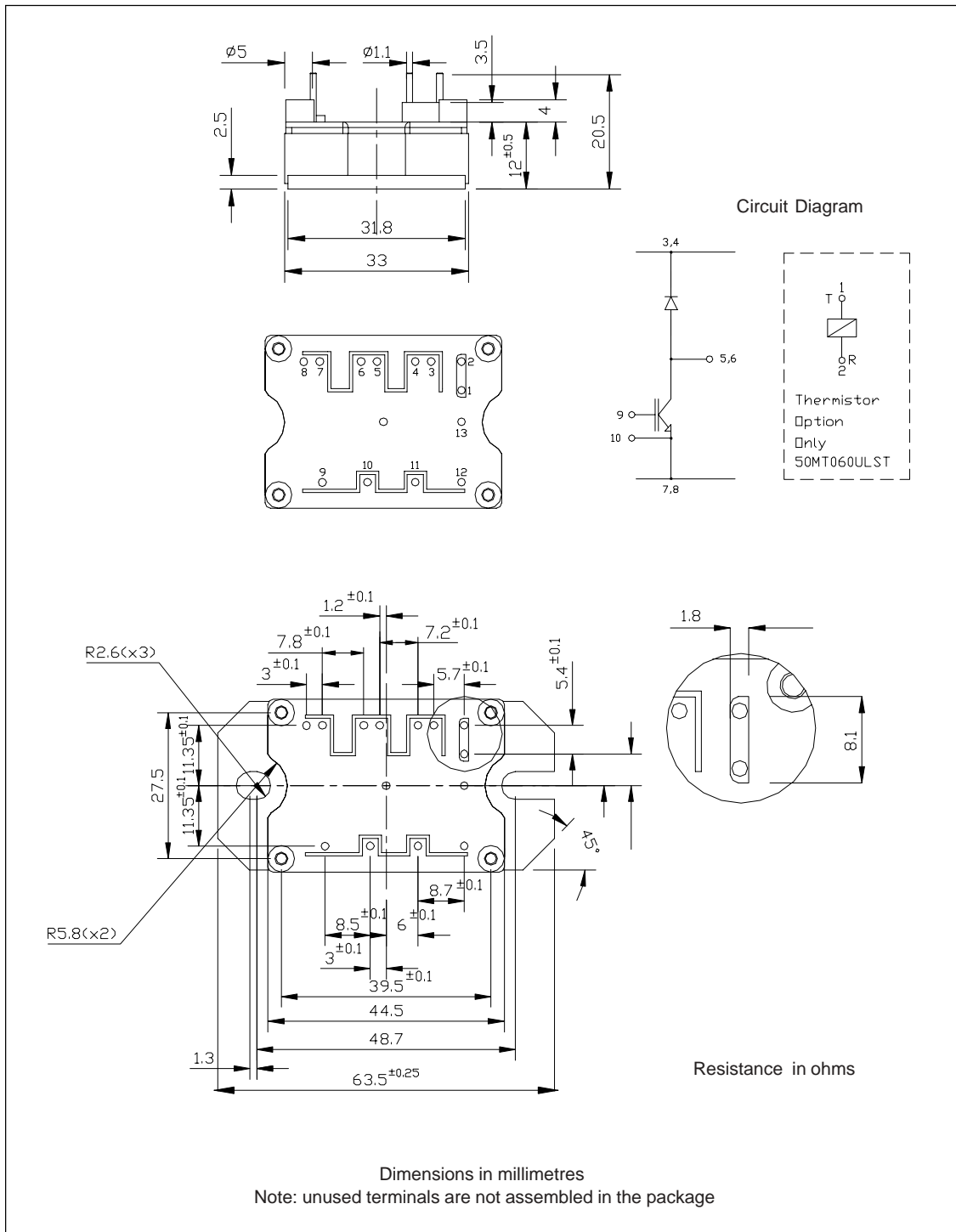

Fig. 1 - Typical Load Current vs. Frequency
(Load Current = I_{RMS} of fundamental)

Outline Table



Ordering Information Table

Device Code

50	MT	060	U	LS	-
①	②	③	④	⑤	⑥

- 1** - Current rating (50 = 50A)
- 2** - Essential Part Number
- 3** - Voltage code (060 = 600V)
- 4** - Speed/ Type (U = Ultra Fast IGBT)
- 5** - Circuit Configuration (LS = Low Side Chopper)
- 6** - Special Option
 - Empty = no special option
 - T = Thermistor

Data and specifications subject to change without notice.
This product has been designed and qualified for Industrial Level.
Qualification Standards can be found on IR's Web site.