



# 40MT120UHA 40MT120UHTA

## "HALF-BRIDGE" IGBT MTP

## UltraFast NPT IGBT

### Features

- UltraFast Non Punch Through (NPT) Technology
- Positive  $V_{CE(ON)}$  Temperature Coefficient
- 10 $\mu$ s Short Circuit Capability
- HEXFRED™ Antiparallel Diodes with UltraSoft Reverse Recovery and Low  $V_F$
- Square RBSOA
- Al<sub>2</sub>O<sub>3</sub> DBC
- Optional SMD Thermistor (NTC)
- Very Low Stray Inductance Design for High Speed Operation

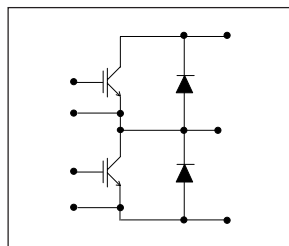

$V_{CES} = 1200V$   
 $I_C = 80A$

### Benefits

- Optimized for Welding, UPS and SMPS Applications
- Rugged with UltraFast Performance
- Benchmark Efficiency above 20KHz
- Outstanding ZVS and Hard Switching Operation
- Low EMI, requires Less Snubbing
- Excellent Current Sharing in Parallel Operation
- Direct Mounting to Heatsink
- PCB Solderable Terminals
- Very Low Junction-to-Case Thermal Resistance

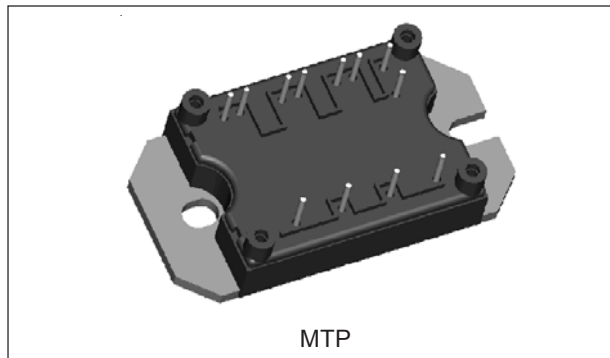

### Absolute Maximum Ratings

Parameters		Max	Units	
$V_{CES}$	Collector-to-Emitter Breakdown Voltage	1200	V	
$I_C$	Continuous Collector Current	@ $T_C = 22^\circ C$	80	
		@ $T_C = 104^\circ C$	40	
$I_{CM}$	Pulsed Collector Current	160	A	
$I_{LM}$	Clamped Inductive Load Current	160		
$I_F$	Diode Continuous Forward Current	@ $T_C = 105^\circ C$		21
$I_{FM}$	Diode Maximum Forward Current			160
$V_{GE}$	Gate-to-Emitter Voltage	$\pm 20$		V
$V_{ISOL}$	RMS Isolation Voltage, Any Terminal to Case, t = 1 min	2500		
$P_D$	Maximum Power Dissipation (only IGBT)	@ $T_C = 25^\circ C$	463	
		@ $T_C = 100^\circ C$	185	
			W	

**Electrical Characteristics @ T<sub>J</sub> = 25°C (unless otherwise specified)**

Parameters	Min	Typ	Max	Units	Test Conditions	
V <sub>(BR)CES</sub> Collector-to-Emitter Breakdown Voltage	1200			V	V <sub>GE</sub> = 0V, I <sub>C</sub> = 250μA	
ΔV <sub>(BR)CES</sub> /ΔT <sub>J</sub> Temperature Coeff. of Breakdown Voltage		+1.1		V/°C	V <sub>GE</sub> = 0V, I <sub>C</sub> = 3mA (25-125°C)	
V <sub>CE(ON)</sub> Collector-to-Emitter Saturation Voltage		3.36	3.59	V	V <sub>GE</sub> = 15V, I <sub>C</sub> = 40A	
		4.53	4.91		V <sub>GE</sub> = 15V, I <sub>C</sub> = 80A	
		3.88	4.10		V <sub>GE</sub> = 15V, I <sub>C</sub> = 40A T <sub>J</sub> = 150°C	
		5.35	5.68		V <sub>GE</sub> = 15V, I <sub>C</sub> = 80A T <sub>J</sub> = 150°C	
V <sub>GE(th)</sub> Gate Threshold Voltage	4		6	V	V <sub>CE</sub> = V <sub>GE</sub> , I <sub>C</sub> = 500μA	
ΔV <sub>GE(th)</sub> /ΔT <sub>J</sub> Temperature Coeff. of Threshold Voltage		-12		mV/°C	V <sub>CE</sub> = V <sub>GE</sub> , I <sub>C</sub> = 1mA (25-125°C)	
g <sub>fe</sub> Transconductance		35		S	V <sub>CE</sub> = 50V, I <sub>C</sub> = 40A, PW = 80μs	
I <sub>CES</sub> Zero Gate Voltage Collector Current			250	μA	V <sub>GE</sub> = 0V, V <sub>CE</sub> = 1200V, T <sub>J</sub> = 25°C	
			0.4	1.0	mA	V <sub>GE</sub> = 0V, V <sub>CE</sub> = 1200V, T <sub>J</sub> = 125°C
			0.2	10		V <sub>GE</sub> = 0V, V <sub>CE</sub> = 1200V, T <sub>J</sub> = 150°C
I <sub>GES</sub> Gate-to-Emitter Leakage Current			±250	nA	V <sub>GE</sub> = ± 20V	

**Switching Characteristics @ T<sub>J</sub> = 25°C (unless otherwise specified)**

Parameters	Min	Typ	Max	Units	Test Conditions
Q <sub>g</sub> Total Gate Charge (turn-on)		399	599	nC	I <sub>C</sub> = 40A V <sub>CC</sub> = 600V V <sub>GE</sub> = 15V
Q <sub>ge</sub> Gate-Emitter Charge (turn-on)		43	65		
Q <sub>gc</sub> Gate-Collector Charge (turn-on)		187	281		
E <sub>on</sub> Turn-On Switching Loss		1142	1713	μJ	V <sub>CC</sub> = 600V, I <sub>C</sub> = 40A V <sub>GE</sub> = 15V, R <sub>g</sub> = 5Ω, L = 200μH T <sub>J</sub> = 25°C, Energy losses include tail and diode reverse recovery
E <sub>off</sub> Turn-Off Switching Loss		1345	2018		
E <sub>tot</sub> Total Switching Loss		2487	3731		
E <sub>on</sub> Turn-On Switching Loss		1598	2397	μJ	V <sub>CC</sub> = 600V, I <sub>C</sub> = 40A V <sub>GE</sub> = 15V, R <sub>g</sub> = 5Ω, L = 200μH T <sub>J</sub> = 125°C, Energy losses include tail and diode reverse recovery
E <sub>off</sub> Turn-Off Switching Loss		1618	2427		
E <sub>tot</sub> Total Switching Loss		3216	4824		
C <sub>ies</sub> Input Capacitance		5521	8282	pF	V <sub>GE</sub> = 0V V <sub>CC</sub> = 30V f = 1.0 MHz
C <sub>oes</sub> Output Capacitance		380	570		
C <sub>res</sub> Reverse Transfer Capacitance		171	257		
RBSOA Reverse Bias Safe Operating Area	full square				T <sub>J</sub> = 150°C, I <sub>C</sub> = 160A V <sub>CC</sub> = 1000V, V <sub>p</sub> = 1200V R <sub>g</sub> = 5Ω, V <sub>GE</sub> = +15V to 0V
SCSOA Short Circuit Safe Operating Area	10			μs	T <sub>J</sub> = 150°C V <sub>CC</sub> = 900V, V <sub>p</sub> = 1200V R <sub>g</sub> = 5Ω, V <sub>GE</sub> = +15V to 0V

**Diode Characteristics @ T<sub>J</sub> = 25°C (unless otherwise specified)**

Parameters		Min	Typ	Max	Units	Test Conditions
V <sub>FM</sub>	Diode Forward Voltage Drop		2.98	3.38	V	I <sub>C</sub> = 40A
			3.90	4.41		I <sub>C</sub> = 80A
			3.08	3.39		I <sub>C</sub> = 40A, T <sub>J</sub> = 125°C
			4.29	4.72		I <sub>C</sub> = 80A, T <sub>J</sub> = 125°C
			3.12	3.42		I <sub>C</sub> = 40A, T <sub>J</sub> = 150°C
E <sub>rec</sub>	Reverse Recovery Energy of the Diode		574	861	μJ	V <sub>GE</sub> = 15V, R <sub>g</sub> = 5Ω, L = 200μH
t <sub>rr</sub>	Diode Reverse Recovery Time		120	180	ns	V <sub>CC</sub> = 600V, I <sub>C</sub> = 40A
I <sub>rr</sub>	Peak Reverse Recovery Current		43	65	A	T <sub>J</sub> = 125°C

**Thermistor Specifications (40MT120UHTA only)**

Parameters		Min	Typ	Max	Units	Test Conditions
R <sub>0</sub> <sup>(1)</sup>	Resistance		30		kΩ	T <sub>0</sub> = 25°C
β <sup>(1)(2)</sup>	Sensitivity index of the thermistor material		4000		K	T <sub>0</sub> = 25°C T <sub>1</sub> = 85°C

<sup>(1)</sup> T<sub>0</sub>, T<sub>1</sub> are thermistor's temperatures

$$\sup(2) \frac{R_0}{R_1} = \exp \left[ \beta \left( \frac{1}{T_0} - \frac{1}{T_1} \right) \right], \text{ Temperatures in Kelvin}$$

**Thermal- Mechanical Specifications**

Parameters		Min	Typ	Max	Units
T <sub>J</sub>	Operating Junction Temperature Range	- 40		150	°C
T <sub>STG</sub>	Storage Temperature Range	- 40		125	
R <sub>thJC</sub>	Junction-to-Case	IGBT		0.29	°C/ W
		Diode		0.61	
R <sub>thCS</sub>	Case-to-Sink (Heatsink Compound Thermal Conductivity = 1 W/mK)		0.06		
	Clearance (external shortest distance in air between two terminals)	5.5			mm
	Creepage (shortest distance along external surface of the insulating material between 2 terminals)	8			
T	Mounting torque to heatsink (3)		3 ± 10%		Nm
Wt	Weight		66		g (oz)

(3) A mounting compound is recommended and the torque should be checked after 3 hours to allow for the spread of the compound. Lubricated threads

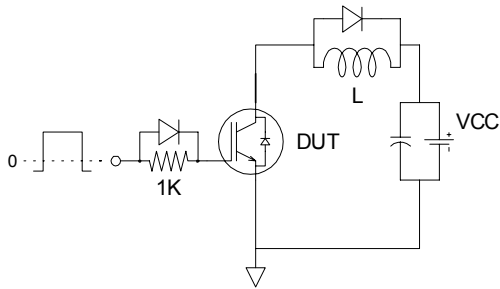

Fig. CT.1 - Gate Charge Circuit (turn-off)

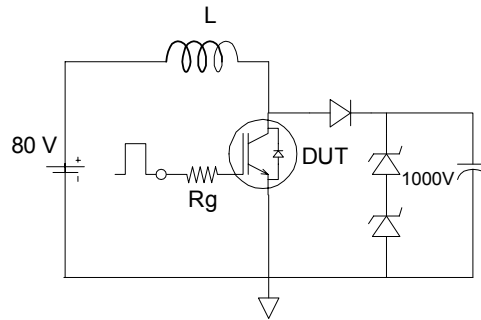

Fig. CT.2 - RBSOA Circuit

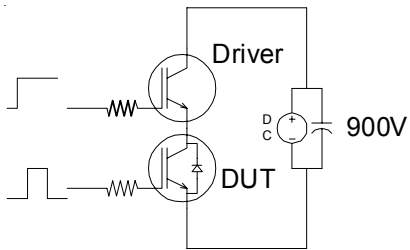

Fig. CT.3 - S.C. SOA Circuit

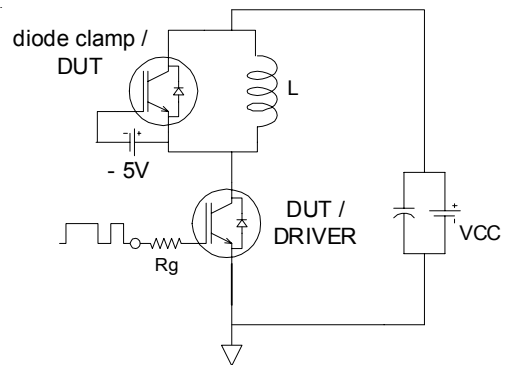
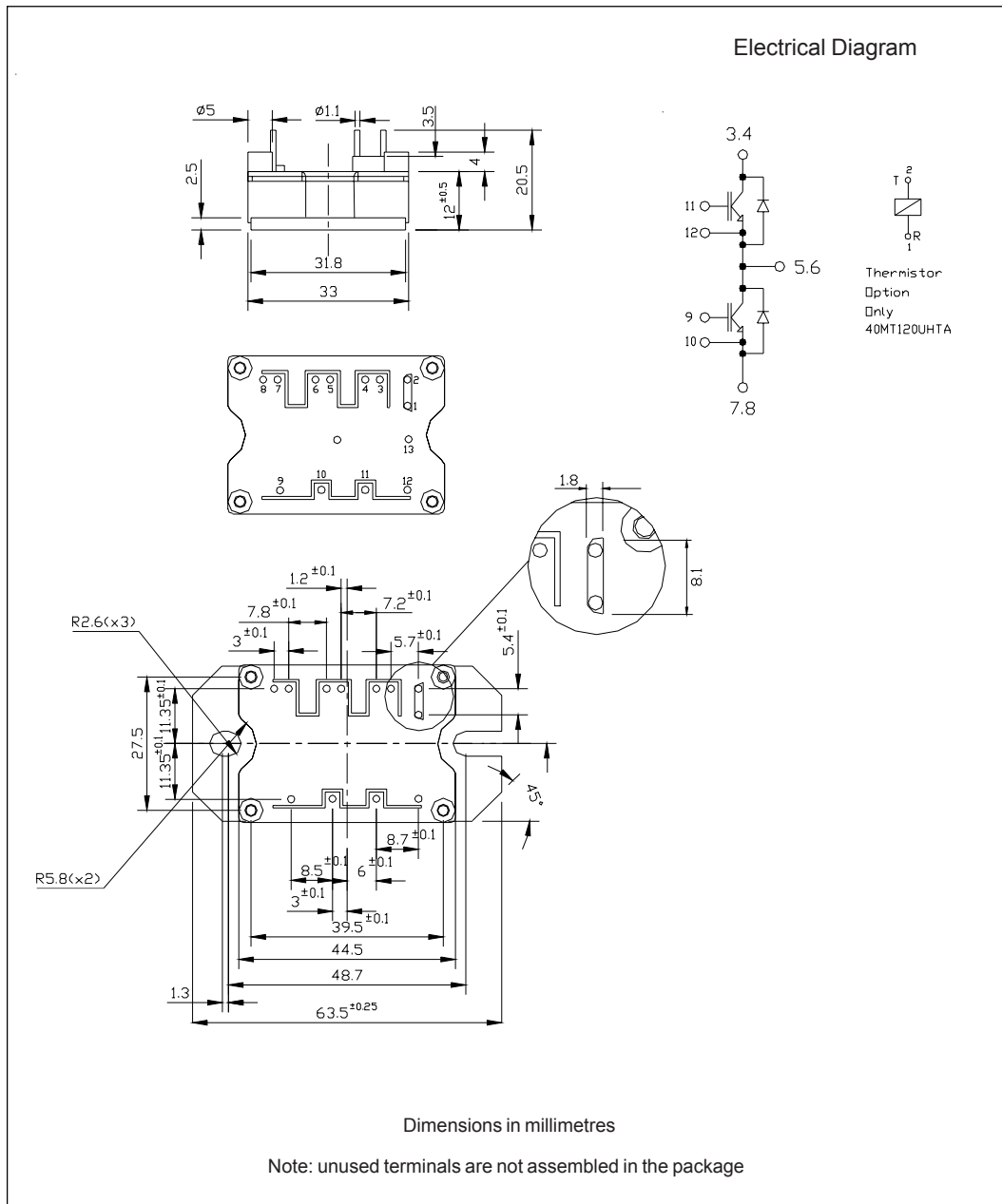

Fig. CT.4 - Switching Loss Circuit

Outline Table



### Ordering Information Table

Device Code	
40	MT
120	U
H	T
A	
(1)	(2)
(3)	(4)
(5)	(6)
(7)	

<b>1</b>	-	Current rating	(40 = 40A)
<b>2</b>	-	Essential Part Number	
<b>3</b>	-	Voltage code	(120 = 1200V)
<b>4</b>	-	Speed/ Type	(U = Ultra Fast IGBT)
<b>5</b>	-	Circuit Configuration	(H = Half Bridge)
<b>6</b>	-	Special Option	
		• none =	no special option
		• T =	Thermistor
<b>7</b>	-	A =	Al <sub>2</sub> O <sub>3</sub> DBC Substrate

Data and specifications subject to change without notice.  
 This product has been designed and qualified for Industrial Level.  
 Qualification Standards can be found on IR's Web site.