

Fuji Discrete Package IGBT

■ Features

- Square RBSOA
- Low Saturation Voltage
- Less Total Power Dissipation
- Minimized Internal Stray Inductance

■ Applications

- High Power Switching
- A.C. Motor Controls
- D.C. Motor Controls
- Uninterruptible Power Supply

■ Outline Drawing

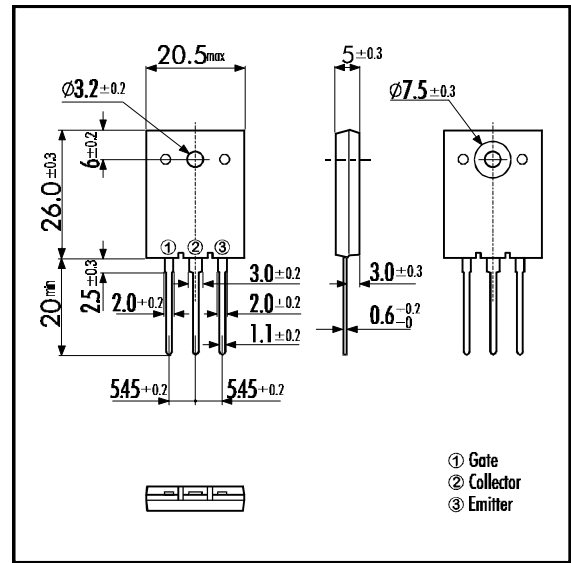

■ Maximum Ratings and Characteristics

• Absolute Maximum Ratings ($T_c=25^\circ\text{C}$)

Items	Symbols	Ratings	Units
Collector-Emitter Voltage	V_{CES}	600	V
Gate -Emitter Voltage	V_{GES}	± 20	V
Collector Current	DC $T_c=25^\circ\text{C}$	I_{C25}	82
	DC $T_c=100^\circ\text{C}$	I_{C100}	50
	1ms $T_c=25^\circ\text{C}$	I_{CPULSE}	328
IGBT Max. Power Dissipation	P_C	310	W
Operating Temperature	T_j	+150	$^\circ\text{C}$
Storage Temperature	T_{stg}	-40 ~ +150	$^\circ\text{C}$
Mounting Screw Torque		70	Nm

■ Equivalent Circuit

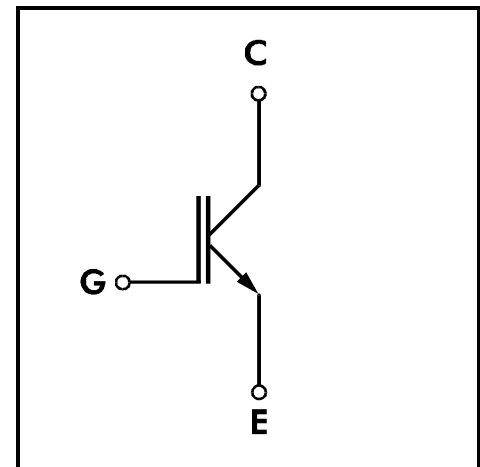

• Electrical Characteristics (at $T_j=25^\circ\text{C}$)

Items	Symbols	Test Conditions	Min.	Typ.	Max.	Units	
Zero Gate Voltage Collector Current	I_{CES}	$V_{GE}=0V$ $V_{CE}=600V$			1.0	mA	
Gate-Emitter Leakage Current	I_{GES}	$V_{CE}=0V$ $V_{GE}=\pm 20V$			20	μA	
Gate-Emitter Threshold Voltage	$V_{GE(th)}$	$V_{GE}=20V$ $I_C=50\text{mA}$	5.5		8.5	V	
Collector-Emitter Saturation Voltage	$V_{CE(sat)}$	$V_{GE}=15V$ $I_C=50\text{A}$			3.0	V	
Input capacitance	C_{ies}	$V_{GE}=0V$		3000		pF	
Output capacitance	C_{oes}	$V_{CE}=10V$		650			
Reverse Transfer capacitance	C_{res}	$f=1\text{MHz}$		150			
Switching Time	Turn-on Time	t_{ON}	$V_{CC}=300V$ $I_C=50A$ $V_{GE}=\pm 15V$ $R_G=62\Omega$		1.2	μs	
		t_r			0.6		
	Turn-off Time	t_{OFF}			1.0		
		t_f			0.35		
	Turn-on Time	t_{ON}	$V_{CC}=300V$ $I_C=50A$ $V_{GE}=\pm 15V$ $R_G=6\Omega$		0.16	μs	
		t_r			0.11		
		Turn-off Time		t_{OFF}			0.30
				t_f			0.35

• Thermal Characteristics

Items	Symbols	Test Conditions	Min.	Typ.	Max.	Units
Thermal Resistance	$R_{th(j-c)}$				0.40	$^\circ\text{C/W}$